

PILOT OPERATED SOLENOID VALVES

PC / RC06,08,15 Series

Rubber Seal, Sub-base Mounting

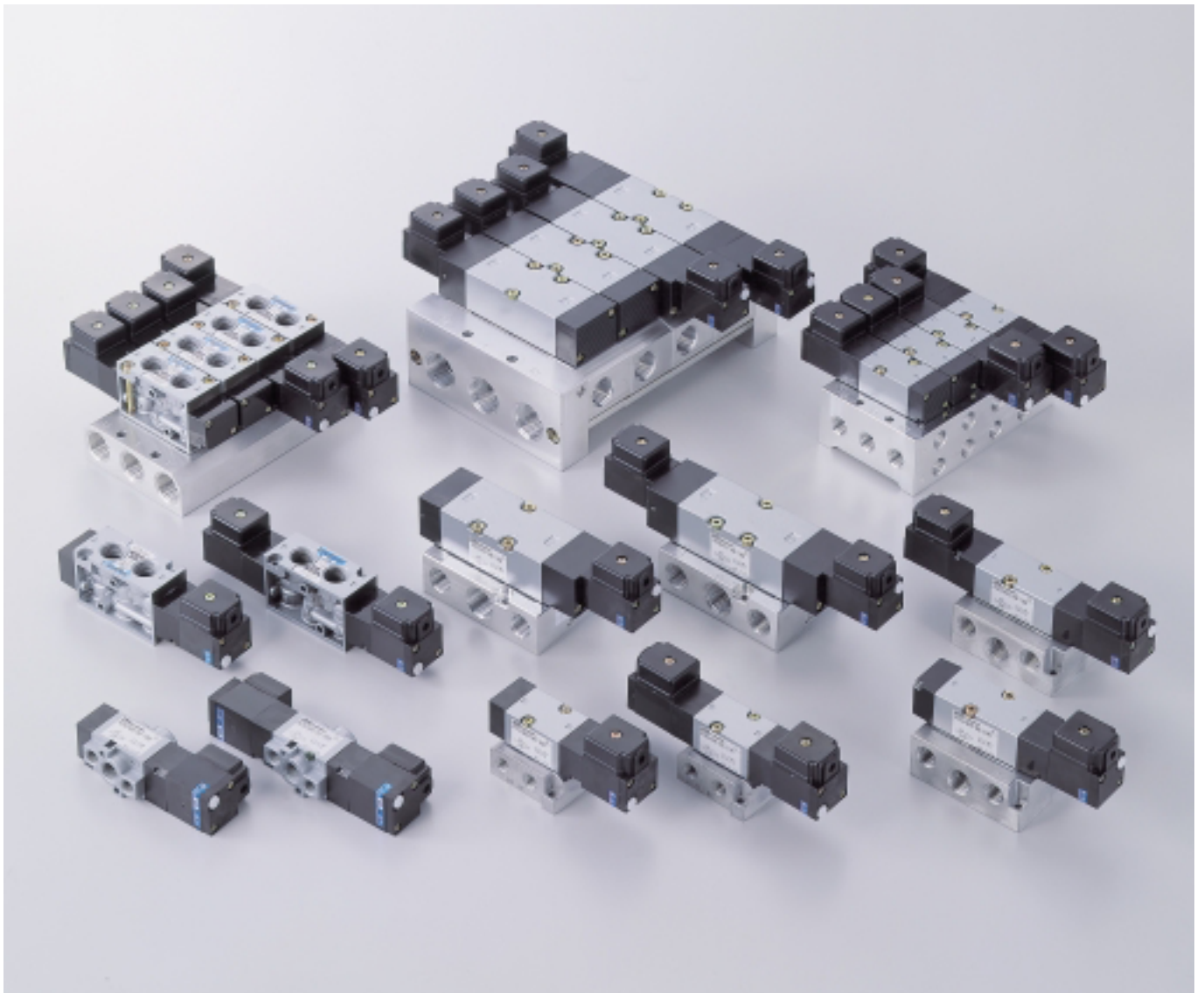

KURODA

ENGINEERING YOUR SUCCESS.

RUBBER SEAL, PILOT OPERATED SOLENOID VALVES

PC/RC06, 08, 15 series

High flow from compact die casted body.

Single piece spool with patented TS seal rings featuring wear compensation design for long life.

Unique solenoid design minimizes burn-out and power consumption.

4-way, 4/5-port, 2/3-position valves, In-line, Sub-base and manifold.

Manual override (None locking type) is standard on all PC/RC series.

Locking type is available on request.

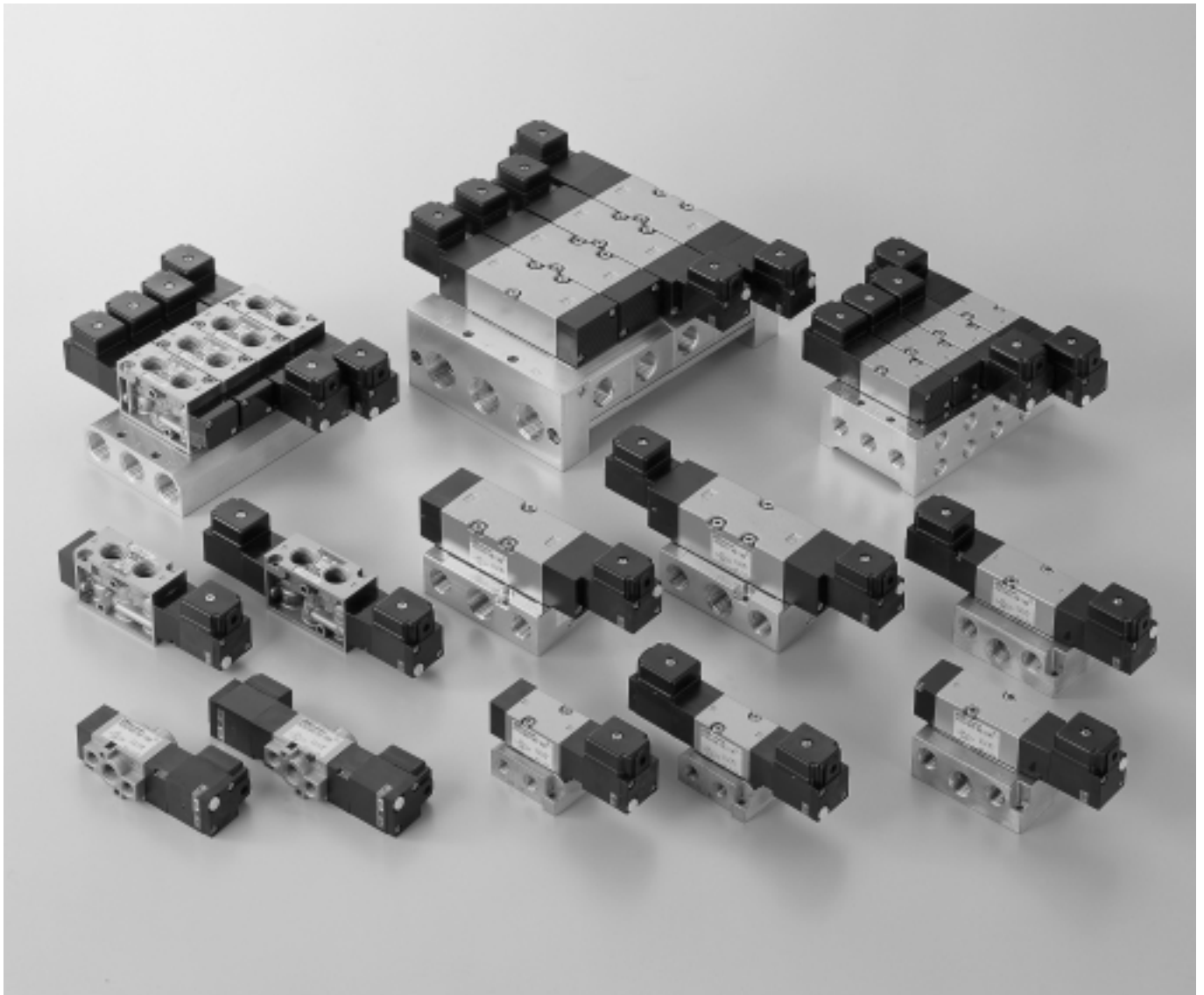

VARIATIONS

Mounting

Sub-base type

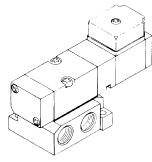

In-line type

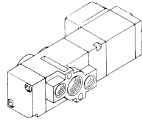

With mounting bracket

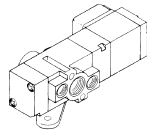

Manifold

MFB -PC06

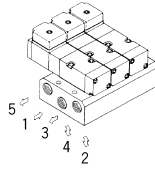

MF -PC08

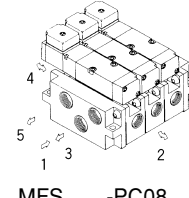

MF -PC15

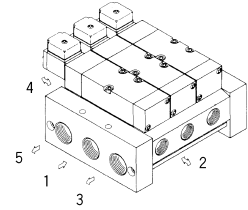

MFS -PC06

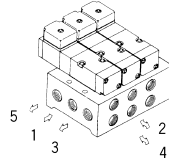

MFS -PC08

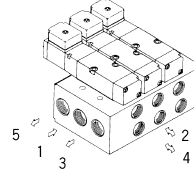

MFU -RC06

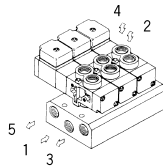

MFU -RC08

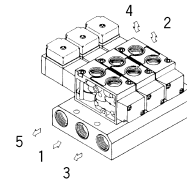

Model No.

PCS24 RCS24

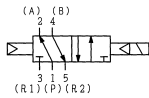

PCD24 RCD24

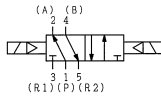

PCD34 RCD34

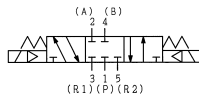

PCE34 RCE34

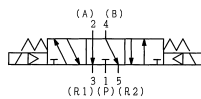

PCO34 RCO34

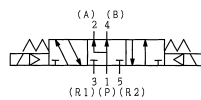

Wiring

Lead wire

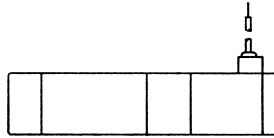

Grommet with terminal

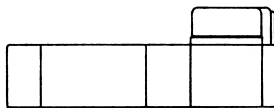

Conduit with terminal
DIN connector

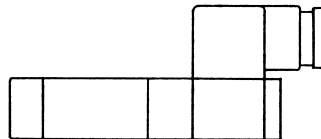

Voltage

AC100/110V

AC200/220V

DC24V

Option & Special specifications

With surge suppressor

With locking override

External pilot

CONTENTS

FEATURES	P.1
VARIATION	P.2
INTRODUCTION OF KURODA CAD DATA LIBRARY	P.3
FOR SAFETY USE	P.4
SOLENOID VALVE/COMMON INSTRUCTIONS	P.5
PC/RC06, 08,15 series/INDIVIDUAL INSTRUCTIONS	P.9
5 PORT PAILOT OPERATED SOLENOID VALVE PC06 series	P.11
INDIVIDUAL WIRING TYPE MANIFOLD MF -PC06	P.15
5 PORT PAILOT OPERATED SOLENOID VALVE PC08 series	P.18
INDIVIDUAL WIRING TYPE MANIFOLD MF -PC08	P.22
5 PORT PAILOT OPERATED SOLENOID VALVE PC15 series	P.25
INDIVIDUAL WIRING TYPE MANIFOLD MF -PC15	P.29
5 PORT PAILOT OPERATED SOLENOID VALVE RC06 series	P.32
INDIVIDUAL WIRING TYPE MANIFOLD MF -RC06	P.36
5 PORT PAILOT OPERATED SOLENOID VALVE RC08 series	P.39
INDIVIDUAL WIRING TYPE MANIFOLD MF -RC08	P.43

INTRODUCTION OF KURODA CAD DATA LIBRARY

KURODA CAD DATA LIBRARY contains CAD data of pneumatic equipment, ball screws, support units and single-axis modules.

In addition, various tools for selecting pneumatic equipment and ball screws are listed in it. Please use this library to improve the design performance of your FA related equipment.

How to Obtain CAD Data Library

CAD Data Library is available from CD-ROM supplied by our company or our company's Home Page via Internet. For a CD-ROM, please ask KURODA sales representative in charge of your company.

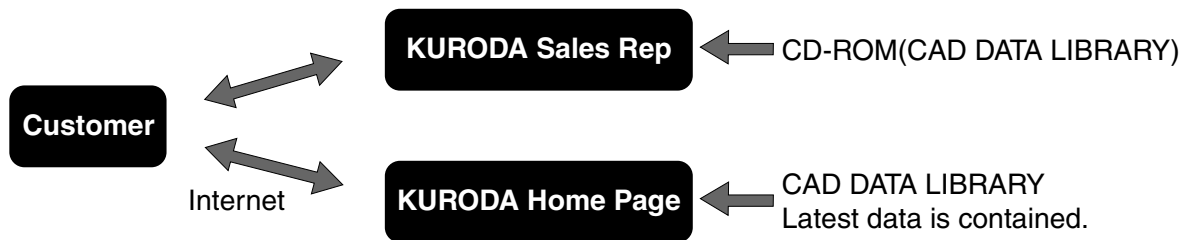

<http://www.kuroda-precision.co.jp/e-top>

Kind of CAD data

Type of data		CD-ROM	Home Page
DXF	r12		
DWG(AUTO CAD) *1	r12		*2

1 : Name of CAD software is our company's registered trademark.
 2 : Some of DWG type product data are not contained

How to Download from Home Page



(Note) CAD data is classified by each product and contained in a self-extracting executable file format (.exe).

CAD Data of Main Pneumatic Equipment

- Pneumatic Actuators
Series of air cylinders and rotary actuators are listed in CAD DATA LIBRARY.
- Pneumatic Grippers/Vacuum Equipment
Series of parallel grippers, rotary opening/closing grippers, vacuum units and pads are listed in it.
- Control Valves
Series of solenoid valves such as ADEX VALVES are listed in it.
- Other Equipment
Series of speed controllers, joints, etc. are listed in it.
- Air Cleaning Equipment
Series of FRL combination QUBE are listed in it.





FOR SAFETY USE

Be sure to read the following instructions before use.
For common and individual instructions, refer to the text of this catalogue.

The following safety precautions are provided to prevent damage and danger to personnel and to provide instructions on the correct usage of this product. These precautions are classified into 3 categories; “CAUTION”, “WARNING” and “DANGER” according to the degree of possible injury or damage and the degree of impendence of such injury or damage.

Be sure to comply with all precautions along with JIS B8370^(※1) and ISO 4414^(※2), as they include important content regarding safety.

- | | |
|------------------|--|
| ⚠ CAUTION | • Indicates a potentially hazardous situation which may arise due to improper handling or operation and could result in personal injury or property-damage-only accidents. |
| ⚠ WARNING | • Indicates a potentially hazardous situation which may arise due to improper handling or operation and could result in serious personal injury or death. |
| ⚠ DANGER | • Indicates an impending hazardous situation which may arise due to improper handling or operation and could result in serious personal injury or death. |

(※1) JIS B8370 : General Rules for Pneumatic Systems

(※2) ISO 4414 : Pneumatic fluid power-General rules relating to systems

⚠ WARNING

● **The applicability of pneumatic equipment to the intended system should be judged by the pneumatic system designer or the personnel who determined specifications for such system.**

As operating conditions for products contained in this catalogue are diversified, the applicability of pneumatic equipment to the intended system should be determined by the pneumatic system designer or the personnel who determined specifications for such system after conducting an analysis or testing as necessary.

The system designer shall be responsible for assuring the intended system performance and safety.

Before making a system, the system designer should thoroughly examine all specifications for such a system and also take into consideration the possibility of any trouble with the equipment.

● **The pneumatic equipment should be handled by persons who have sufficient knowledge and rich experience.**

Inproper handling of compressed air will result in danger.

Assembling, operation and maintenance of machinery using pneumatic equipment should be performed by persons who have sufficient knowledge and rich experience.

● **Never operate machinery nor remove the equipment until safety is assured.**

• Before checking or servicing machinery and equipment, be sure to check that steps for prevention of dropping or runaway of the driven component have been completely taken.

• When removing the equipment, make sure that the above-mentioned safety measures have been done beforehand.

Then turn off air supply and power to the system and purge compressed air in the system.

• When restarting machinery and equipment, check that proper prevention of malfunction has been provided for and then restart carefully.

● **When using the pneumatic equipment in the following conditions or environments, take the proper safety measures and consult KURODA beforehand.**

• Conditions and environments other than specified and outdoor use.

• Applications to nuclear power equipment, railroads, aircraft, vehicles, medical equipment, equipment connected with food and drink, amusement facilities and safety devices such as emergency interruption devices, clutch/brake circuits for a press and the likes.

• Applications which require extreme safety and will also greatly affect men and property.



SOLENOID VALVES/COMMON INSTRUCTIONS

Be sure to read them before use.

Also refer to Par. "For Safety Use" and instructions mentioned for each series of solenoid valves.

DESIGN

! WARNING

• Stopping actuator at intermediate position

When stopping the actuator at an intermediate position using a solenoid valve listed in this catalogue, it is difficult to stop it accurately because of the compressibility of air, unlike a hydraulic cylinder can do.

In addition, as the solenoid valve and air cylinder allow a certain degree of air leak, they cannot stop at the fixed position for a long period of time according to circumstances. When it is required to stop them at the fixed position for a long period of time, contact KURODA.

• Keeping pressure (including vacuum)

As the solenoid valve is designed to allow a certain degree of air leak, it cannot be used to keep pressure (including vacuum) in a pressure vessel etc.

• Do not use for emergency shutoff valves.

Solenoid valves listed in this catalogue are not designed for use in emergency shutoff valves and other safety applications. When using the solenoid valve for such applications, provide an independent means to assure safety.

• Exhausting residual air

Provide a residual air exhausting function in due consideration of maintenance and inspection. Doing maintenance and inspection without exhausting residual air may sometimes malfunction the actuator.

When using a 3-position closed center type solenoid valve, compressed air is shut in between solenoid valve and actuator even if residual air from the air supply side to the solenoid valve is exhausted.

Therefore, provide a means to exhaust the residual air pressure separately.

• Use in vacuum

When using a solenoid valve for diverting vacuum and other applications, check specifications for the valve and select a proper one that can be used in vacuum.

In order to prevent sucking foreign matters from the suction pad and exhaust port, provide an inline filter between the suction pad and solenoid valve and at the exhaust port.

• Applying current continuously for long time

When using a solenoid valve while applying current to it continuously for a long period of time, contact KURODA beforehand.

• Avoid applying current simultaneously.

When using a double-solenoid valve while applying current to it continuously for a long period of time, do not apply current to both solenoids simultaneously; otherwise the coil may be burnt out or the main valve may malfunction.

• Remodeling the solenoid valve

Do not remodel the solenoid valve.

DESIGN

! CAUTION

• Applying current momentarily

When using a double-solenoid type valve, apply current for the prescribed period of time (0.1 sec.). If current is not applied for the prescribed period of time, the solenoid valve may not perform the diverting action according to circumstances.

• Leak current

When a C-R element is used in the contact protective circuit (surge voltage protection), leak current will flow through the C-R element.

If this leak current becomes large, a malfunction will occur. Therefore, reduce leak current to less than 1 mA.

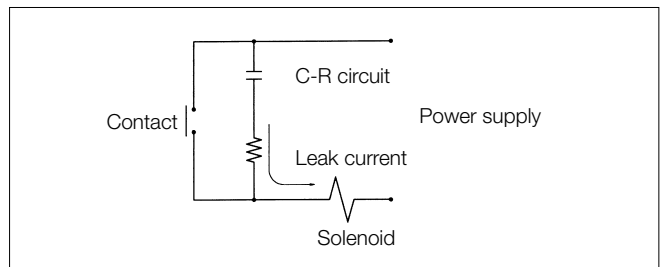

• Use at low temperature

When using a solenoid valve at 5 °C or below, provide an air dryer or other proper means to prevent moisture from solidifying or freezing.

• Use with air blow

When using a solenoid valve with air blow, select a direct-operated type or external pilot type solenoid valve.

When an internal pilot type solenoid valve is used, it may not perform the diverting action due to a pressure drop at the time of air blow.

When an external pilot type solenoid valve is used, supply compressed air within the specified pressure range to the pilot port.

• Mounting position and direction

A solenoid valve can be mounted in any position and direction as a general.

However, a metal seal type double-solenoid valve and a 3-position solenoid valve should be mounted so that the spool may be horizontal.

• Shock and vibration

Reduce shocks and vibrations applied to the solenoid valve to less than the prescribed value. (refer to specifications.)

Applying shocks and vibrations exceeding the prescribed value may result in a malfunction of the solenoid valve.



SOLENOID VALVES/COMMON INSTRUCTIONS

Be sure to read them before use.

Also refer to Par. "For Safety Use" and instructions mentioned for each series of solenoid valves.

SELECTION

! WARNING

- **Refer to specifications.**

Solenoid valves listed in this catalogue are designed for compressed air. When using other fluid than compressed air, contact KURODA beforehand.

Do not use a solenoid valve at pressure and temperature outside the range of specifications, otherwise resulting in a breakdown or malfunction.

MOUNTING

! WARNING

- **When mounting the solenoid valve, firmly fix it while using care to prevent the stationary part and joint from loosening.**

If the solenoid valve is mounted with insufficient strength, it may sometimes come off.

- **Do not start the system until it is ensured that equipment works properly.**

After mounting the solenoid valve, connect power supply and then perform a functional test and a leak test. Check that it has been correctly mounted and works properly, before starting the system.

- **Coating with paint**

When coating the resin portion with paint, it may be adversely affected by paint and solvent. For the propriety of painting, contact KURODA beforehand.

Do not peel off the nameplate affixed on the solenoid valve and do not erase or smear out the letter on it.

- **Provide space for maintenance and inspection.**

! CAUTION

- **Fit an air muffler to the exhaust port (ports 3, 5) of the solenoid valve.**

Dust or foreign matter that enters it may cause a malfunction of the solenoid valve.

- **Do not wipe off the model name inscribed on a nameplate etc. with organic solvent.**

The inscribed indication may be erased.

PIPING

! CAUTION

- **Before piping**

Thoroughly flush the inside of each pipe to remove chips, coolant, dust, etc. before piping.

- **How to wind a seal tape**

When winding a seal tape around the threaded portion, leave space of 1.5 to 2 thread turns.

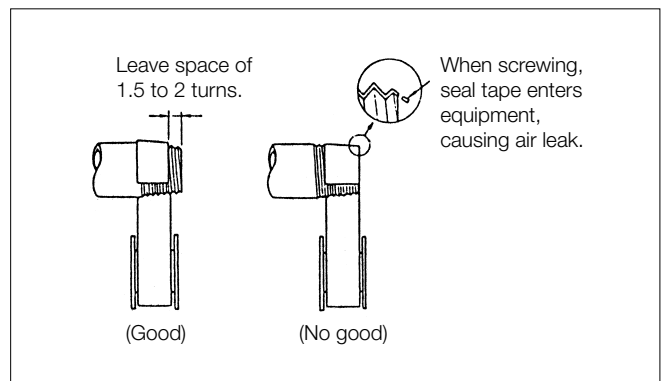

- **How to apply liquid sealant**

When applying liquid sealant to the threaded portion, apply a proper amount to about 1/3 of the periphery of the threaded portion and then screw it.

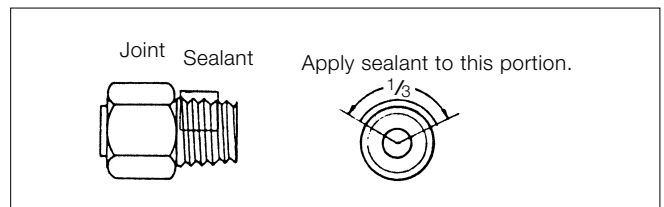

- **Screw of pipe and joint**

When screwing the pipe and joint, use care to prevent chips and sealant from entering the pipe and joint.

Tighten them within a proper range of clamping torque.

Port size	Clamping torque (N·m)
M3	0.3 ~ 0.5
M5	1.5 ~ 2.0
R, Rc ¹ / ₈	7.0 ~ 9.0
R, Rc ¹ / ₄	12 ~ 14
R, Rc ³ / ₈	2 ~ 24
R, Rc ¹ / ₂	28 ~ 30
R, Rc ³ / ₄	28 ~ 30
R, Rc1	36 ~ 38
R, Rc1 ¹ / ₄	40 ~ 42
R, Rc1 ¹ / ₂	48 ~ 50



SOLENOID VALVES/COMMON INSTRUCTIONS

Be sure to read them before use.

Also refer to Par. "For Safety Use" and instructions mentioned for each series of solenoid valves.

PIPING

CAUTION

- **Avoid wrong piping.**

When connecting a pipe to a solenoid valve, be careful not to mistake the supply port by referring to the nameplate affixed to the product or the product catalogue.

- **When using a 3-position closed center type solenoid valve :**

Thoroughly check the piping between solenoid valve and actuator for air leak.

WIRING

WARNING

- **When doing wiring work, be sure to turn off compressed air and power supplies beforehand.**

Wiring work without turning off air and power supplies may cause an electric shock or malfunction ; this sometimes results in an injury to the human body or a damage to property.

- **Avoid mis-wiring.**

Some solenoid valves have polarity : Those operating on DC with built-in indicator light and those equipped with surge protective circuit.

When wiring to a solenoid valve, check whether or not it has polarity.

For a solenoid valve having polarity, check the lead wire color and symbol of the polarity by the catalogue or actual article beforehand and then make correct wiring.

Mis-wiring will result in the following problems :

(Where no polarity protective diode is incorporated :)

Wiring to the wrong polarity will burn out the diode in the solenoid valve, the switching element on the control unit side or the power supply unit.

(Where a polarity protective diode is provided :)

Wiring to the wrong polarity will not cause the solenoid valve to perform a diverting action.

- **Avoid applying stress and tensile force to lead wire repeatedly.**

Wiring made in such a manner that stress and tensile force are repeatedly applied to the lead wire will result in the breaking of wire. Provide some degree of margin for wiring.

- **Check that there is no insulation failure.**

If an insulation failure occurs in the lead wire connection, extension cable and terminal base, an excess flows to the switching element of the solenoid valve or control unit, sometimes resulting in a damage.

- **Do not mistake applied voltage.**

Mistake in applied voltage in case of wiring to a solenoid valve will cause an operation failure or burn out the coil.

- **After completion of wiring, check for wrong connection before turning on power.**

OPERATING ENVIRONMENTS

DANGER

- **Do not use solenoid valve in a explosive environment.**

WARNING

- **Do not use a solenoid valve in atmospheres containing corrosive gases, chemicals, seawater, water and vapor and in places where a solenoid valve contacts these matters.**

- **Do not use a solenoid valve in a place where vibrations or shocks are directly applied to it.**

- **When a solenoid valve is exposed to the direct sunlight, fit a protective cover to the solenoid valve.**

- **When a solenoid valve is located around a heat source, shut off the radiant heat.**

- **When installing a solenoid valve in the control panel, take proper heat-radiating measures so that the inside temperature may be kept within the specified temperature range.**

- **When using a solenoid valve in a place where it is exposed to welding spatters, provide a protective cover or other proper prevention.**

Welding spatars may burn out the plastic parts of the solenoid valve, sometimes resulting in a fire.

LUBRICATION

CAUTION

- **Solenoid valves listed in this catalogue are non-lubrication.**

The non-lubricated solenoid valve can be used without lubrication, but can be used with lubrication.

When using it with lubrication, do not discontinue supplying oil.

Otherwise, the applied lubricant may run off, sometimes resulting in an operation failure.

When using a lubricant, Class 1 turbine oil ISO VG 32 (containing additive) is recommended.



SOLENOID VALVES/COMMON INSTRUCTIONS

Be sure to read them before use.

Also refer to Par. "For Safety Use" and instructions mentioned for each series of solenoid valves.

QUALITY OF AIR

WARNING

- **Use pure air.**

Compressed air containing corrosive gases, chemicals, salt, etc. causes a breakdown or operation failure. So do not use such air.

CAUTION

- **Fit an air filter with filtration of 5 μm or fine.**

- **Install an air dryer.**

Compressed air containing much drainage causes the operation failure of pneumatic equipment. Install an air dryer, lower the temperature and reduce drainage.

- **Take proper countermeasures against sludge.**

If sludge produced in compressor oil enters pneumatic equipment, it will cause the operation failure of pneumatic equipment. It is recommendable to use compressor oil (NISSEKI FAIRCALL A68, IDEMITSU DAPHUNY SUPER CS68) featuring minimized sludge production or use a sludge filter or mist cleaner to prevent sludge from entering the pneumatic equipment.

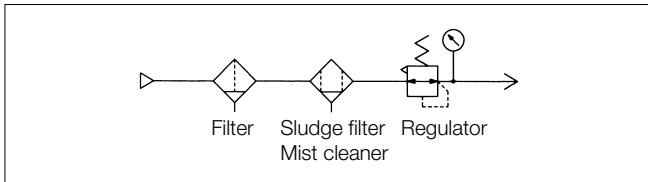

MAINTENANCE AND INSPECTION

WARNING

- **Inspection before maintenance**

First check that load drop prevention has been provided. Then shut off air and power supplies to the system and exhaust residual air in the system beforehand.

For a 3-position closed center type solenoid valve, compressed air is sealed between solenoid valve and cylinder. Exhaust this residual compressed air.

- **Inspection after maintenance**

When restarting the system, check that preventive measures against flying-out of the actuator have been taken. Then connect compressed air supply to the pneumatic system, and perform a proper functional test and a leak test to check that it works safely without fail, before starting the system.

- **Operation at low frequency**

To prevent an operation failure, perform the switching action of the solenoid valve once per 30 days. (Be careful of air supply.)

- **Manual operation**

When the solenoid valve is manually operated, the system connected to it is also operated. Make sure safety before operation.

- **Disassembly of solenoid valve**

When disassembling the solenoid valve, contact KURODA beforehand.

CAUTION

- **Draining**

To keep the quality of air to a certain level, drain the air filter at periodical intervals.



PC/RC06, 08, 15 SERIES/INDIVIDUAL INSTRUCTIONS

Be sure to read them before use.

Also refer to Par. " For Safety Use "and common instructions.

WIRING SPECIFICATIONS

! CAUTION

Terminal of grommet and conduit

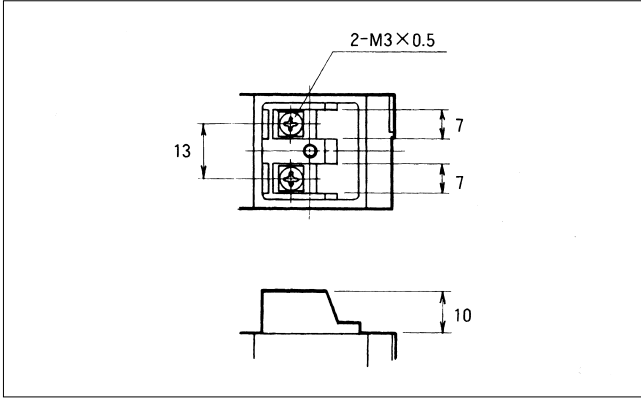

Grommet cover

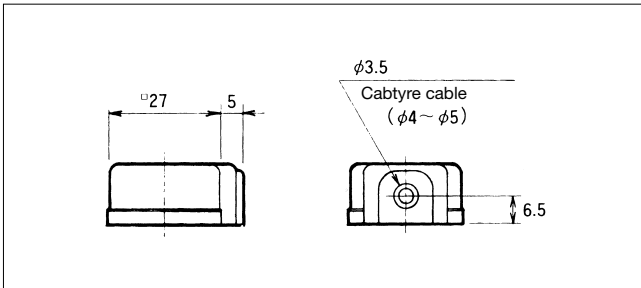

Conduit cover

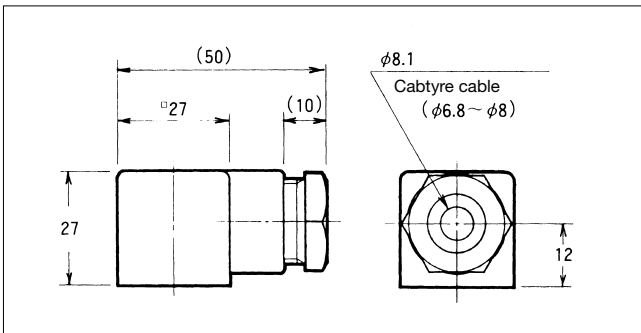

LEAD WIRE SPECIFICATIONS

! CAUTION

0.3mm² × 500 ℓ (O.D. 1.7)
AWG22 (UL1007)

WITH SURGE SUPPRESSOR

! CAUTION

The following varistor type surge suppressor
AC100V TNR9G271K or equivalent of Z7D271
AC200V TNR9G471K or equivalent of Z7D471
DC24V TNR9G470K or equivalent of Z7D470

EXTERNAL PILOT TYPE (Made to order)

! CAUTION

External pilot port position

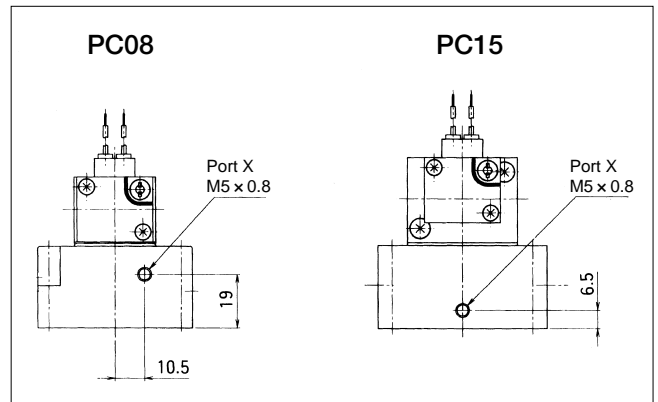



PC/RC06, 08, 15 SERIES/INDIVIDUAL INSTRUCTIONS

Be sure to read them before use.

Also refer to Par. "For Safety Use" and common instructions.

FLOW RATE

Flow rate can be calculated from the following formula :

For values in the sonic velocity zone, find out from the attached table.

$$P_H = 1.89P_L \text{ (Subsonic velocity zone)}$$

$$Q = 240 \times S \times P_L \times (P_H - P_L) \times \frac{293}{T_H}$$

$$P_H = 1.89P_L \text{ (Sonic velocity zone)}$$

$$Q = 120 \times S \times P_H \times \frac{273}{T_H}$$

Q : Flow rate ℓ /min(ANR)

S : Effective area of orifice mm²

P_H : Pressure on upper stream MPa abs

P_L : Pressure on down stream MPa abs

T_H : Absolute temperature on upper stream K

(Note) Absolute pressure (MPa) = Supply pressure + 0.100 (MPa)

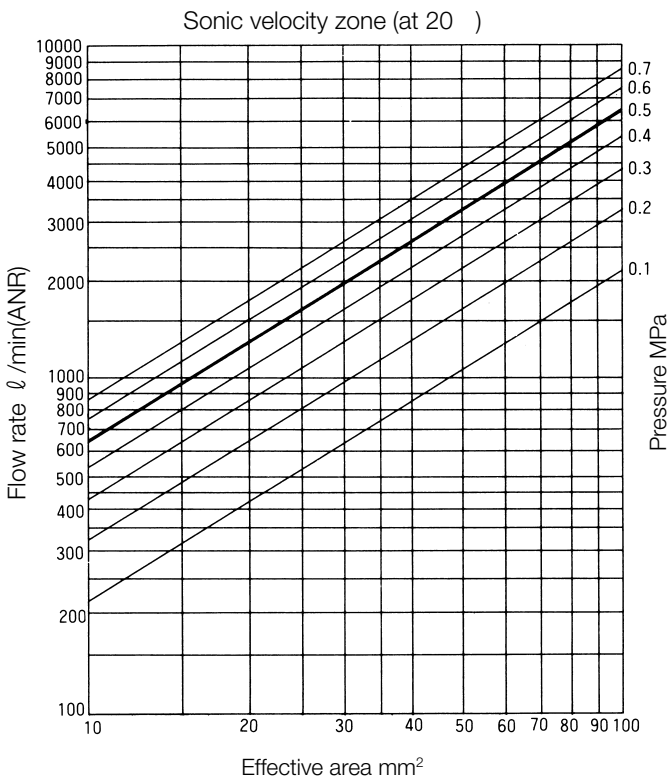

(When the value of effective area is $\times 10^{-1}$ or $\times 10^0$, multiply the same figure by the flow rate.)

EFFECTIVE AREA

Effective areas mentioned in this catalog are measured between ports 1, 2, 4 in accordance with JIS (JAPANESE INDUSTRIAL STANDARD) B8374/8375.

MULTI-PURPOSE FUNCTION

Solenoid valve designed with a balanced spool works as (common) external pilot system so that compressed air can be supplied from any port to provide multi-purpose functions.

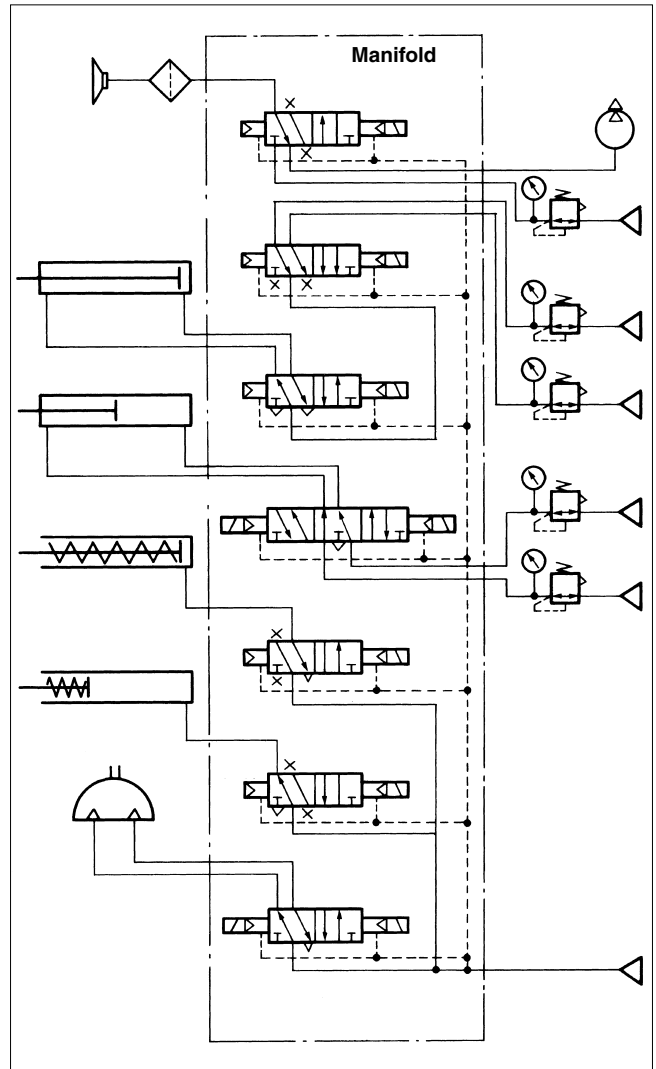

5-PORT PILOT OPERATED SOLENOID VALVES

PC06 Series

Rubber Seal, Sub-base Mounting type

PCS2406	2-position Single solenoid
PCD2406	2-position Double solenoid
PCD3406	3-position Closed center
PCE3406	3-position Exhaust center
PCO3406	3-position Pressure center

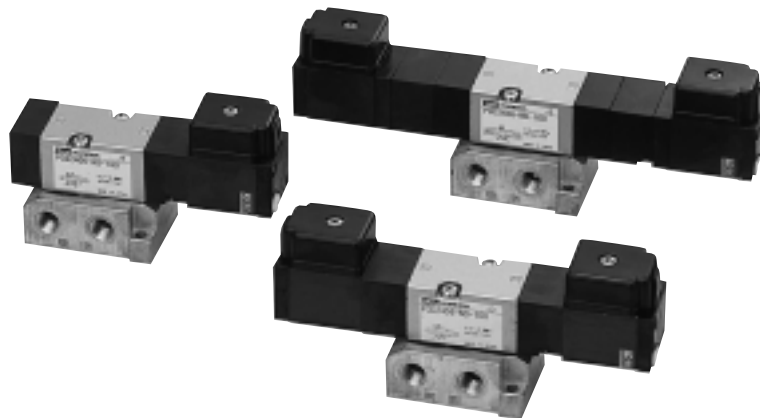

SPECIFICATIONS

Model No.	Unit	PCS2406	PCD2406	PCD3406 PCE3406	PCO3406
Fluid		Non-lubricated/lubricated air			
Port size		Rc ¹ / ₄			
Effective area	mm ²	10			9
Cv value		0.54			0.49
Operating ambient temperature		- 5 ~ 50			
Operating pressure range	MPa	0.2 ~ 0.8			
Maximum frequency	Cycle/min	240			180
Response time at 0.5MPa	s	ON 0.021 OFF 0.021	ON 0.015		ON 0.025 OFF 0.035
Rated voltage	V	AC100/110、200/220、DC24			
Grade of insulation		JIS grade B			
Permissible voltage fluctuation	%	AC ± 10、DC ⁺¹⁰ / ₋₁₅			
Rated frequency	Hz	50/60			
Power consumption	AC	Holding	50Hz	VA	(100/200) 3.2
			60Hz	VA	(100/200) 2.6
		Inrush	50Hz	VA	(100/200) 5
			60Hz	VA	(100/200) 4.5
Power consumption DC	W	2			
Wiring		Lead wire, Grommet with terminal, Conduit with terminal, DIN connector			
Mass	kg	0.2	0.27	0.36	0.36

(Note) • When temperature of valve site goes down below 5 °C, complete dry air shall be supplied to prevent from freezing.
 • Effective area shown above is value between ports 1 and 2, 4.
 • Response time shown above is in accordance with JIS B 8375.

ORDERING INSTRUCTION

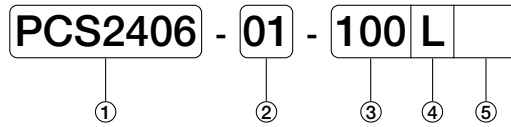

① Model No.

PCS2406	
PCD2406	
PCD3406	
PCE3406	
PCO3406	

④ Wiring

L	Lead wire
G	Grommet with terminal
C	Conduit with terminal
GK	Grommet with surge suppressor
CK	Conduit with surge suppressor
D	DIN connector

⑤ Manual override

No mark	Standard (None locking)
L	With locking button

: Made to order

② Port size

02	Rc ¹ / ₄
NB	Without sub-base

③ Voltage

100	AC100/110V
200	AC200/220V
D24	DC24V

CONSTRUCTION

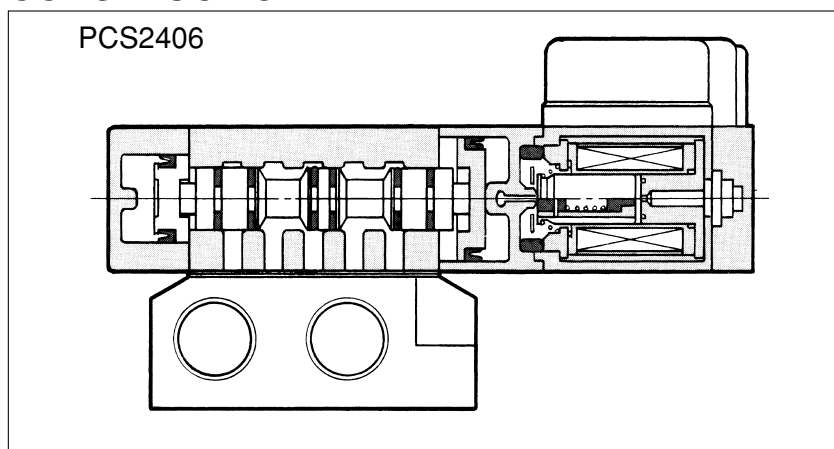

SPARE PARTS

Sub-base

Port size	Model No.
Rc ¹ / ₄	PC06-SB-02

PC06 Series

DIMENSIONS

PCS2406

(Unit : mm)

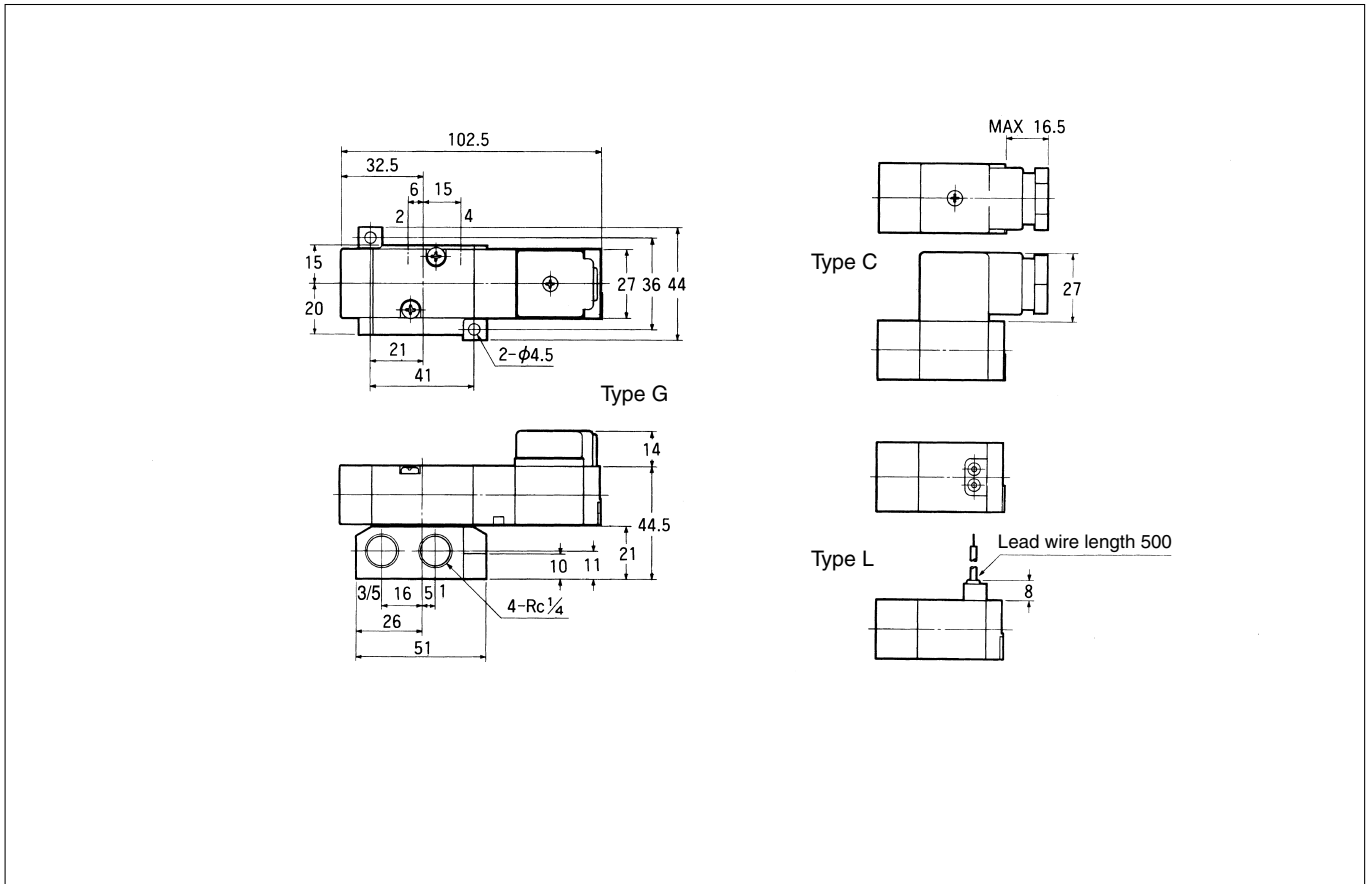

PCD2406

(Unit : mm)

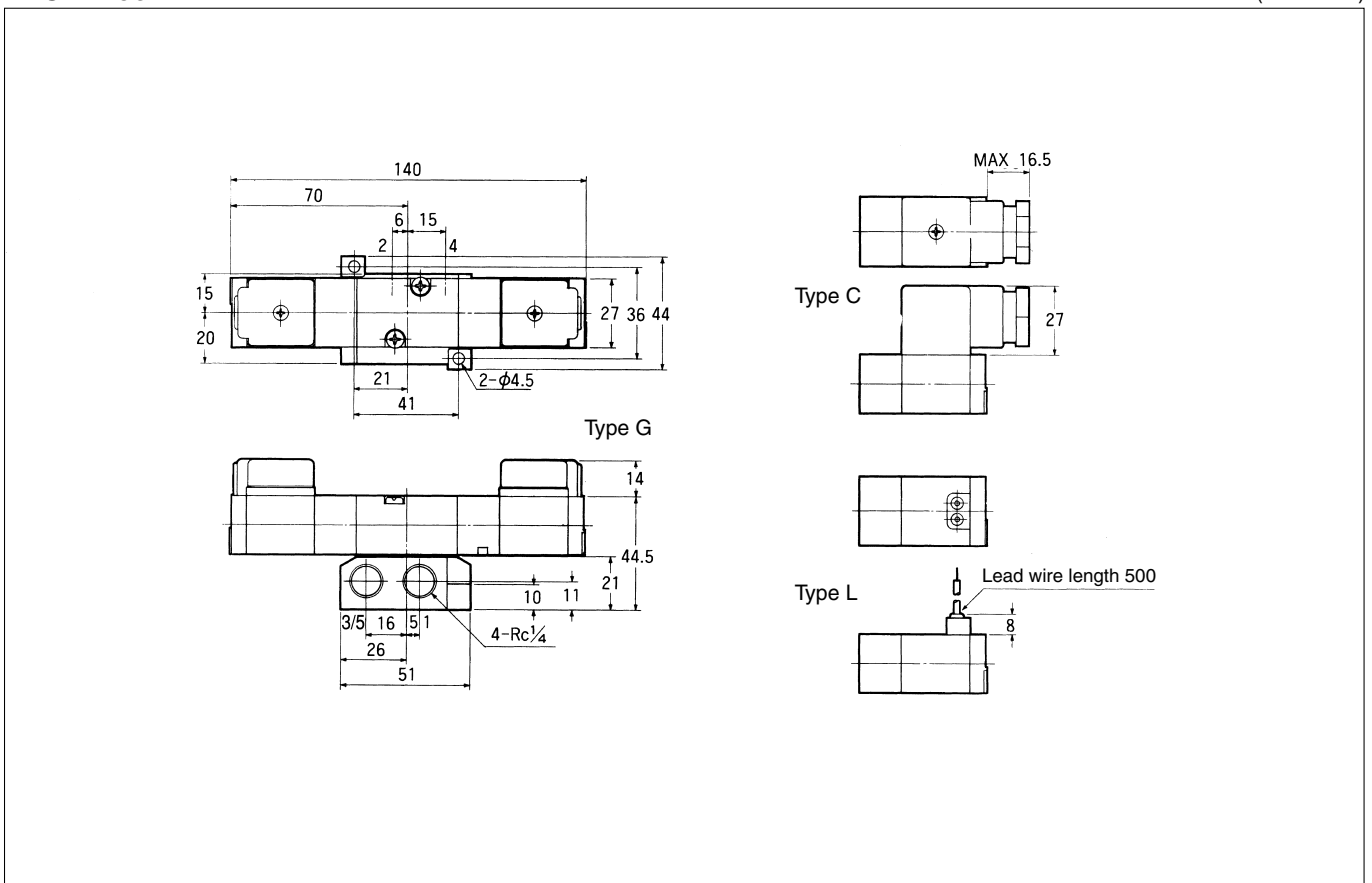

DIMENSIONS

PCD3406, PCE3406, PCO3406

(Unit : mm)

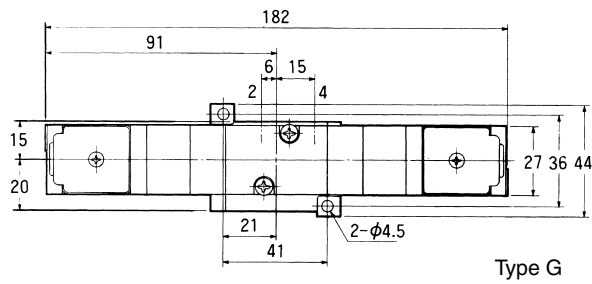

Type G

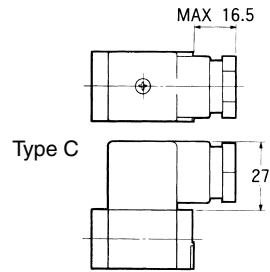
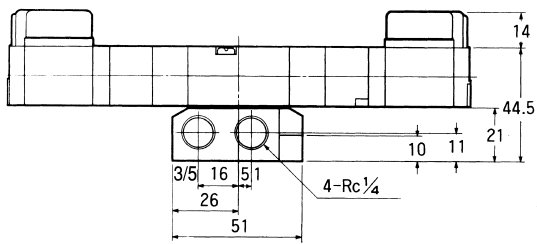

Type C

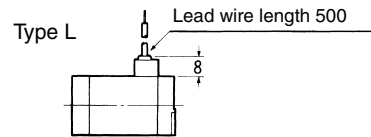
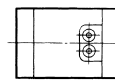

Type L

INDIVIDUAL WIRING TYPE MANIFOLD

MF -PC06

Bar type

MFS -PC06 Common SUP, Common EXH
Ports 2 & 4 on side

MFB -PC06 Common SUP, Common EXH
Ports 2 & 4 on bottom

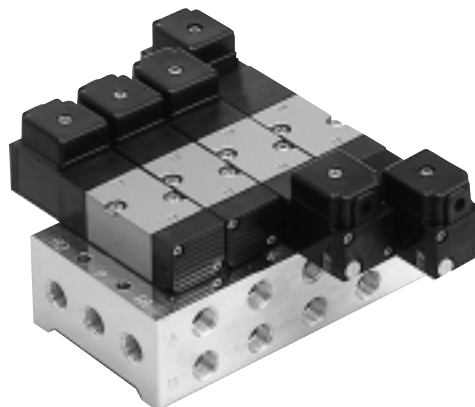

MANIFOLD SPECIFICATIONS

Type of manifold		MFS -PC06 Common SUP, common EXH Ports 2 & 4 on side	MFB -PC06 Common SUP, common EXH Ports 2 & 4 on bottom
Port size	Port 1	Rc ¹ / ₄ (Both sides)	Rc ¹ / ₄ (Both sides)
	Port 3, 5	Rc ¹ / ₄ (Both sides)	Rc ¹ / ₄ (Both sides)
	Port 2, 4	Rc ¹ / ₄ (Side)	Rc ¹ / ₄ (Bottom side)
Number of stations		2 ~ 10	
Mountable solenoid valve		PCS2406-NB- PCD2406-NB- PCD3406-NB- PCE3406-NB- PCO3406-NB-	
Blank plate		PC06-BP	

HOW TO ORDER

Specify the type and quantity of Manifold and Solenoid Valve to be mounted, and the quantity of Blank Plate (PC06-BP) in accordance with the following example of description.

(Example) **MFS8-PC06-02**

PCS2406-NB-100G	4 pcs.
PCD2406-NB-100G	2 pcs.
PCD3406-NB-100G	1 pc.
PC06-BP	1 pc.

ORDERING INSTRUCTION

Manifold

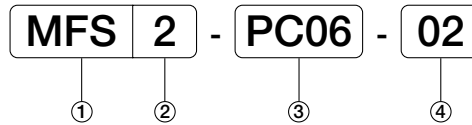

① Type of manifold

MFS	Common SUP, common EXH Ports 2 & 4 on side
MFB	Common SUP, Common EXH Ports 2 & 4 on bottom

③ Mountable solenoid valve

PC06	PC06 series
------	-------------

④ Size of ports 2 and 4

02	Rc $\frac{1}{4}$
----	------------------

② Number of stations

2	2 station
⋮	⋮
10	10 station

Mountable solenoid valve (For details refer to Pages 11 to 14.)

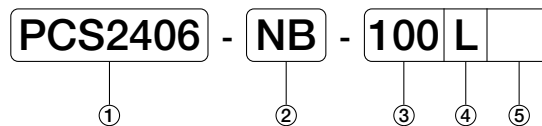

① Model No.

PCS2406	
PCD2406	
PCD3406	
PCE3406	
PCO3406	

④ Wiring

L	Lead wire
G	Grommet with terminal
C	Conduit with terminal
GK	Grommet with surge suppressor
CK	Conduit with surge suppressor
D	DIN connector

⑤ Manual override

No mark	Standard (None locking)
L	With locking button

: Made to order

② Port size

NB	Without sub-base
----	------------------

③ Voltage

100	AC100/110V
200	AC200/220V
D24	DC24V

PC06 Series

DIMENSIONS

MFS -PC06-02

(Unit : mm)

(Note) Standard manifold is plugged on " R " (Right) side ports.

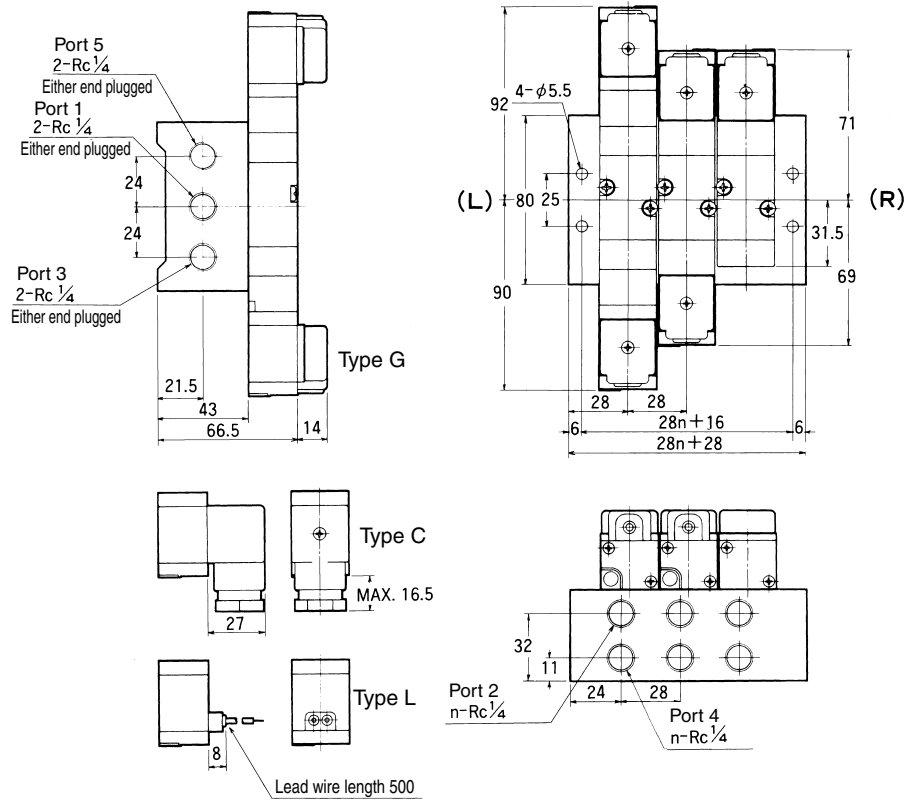

MFB -PC06-02

(Unit : mm)

(Note) Standard manifold is plugged on " R " (Right) side ports.

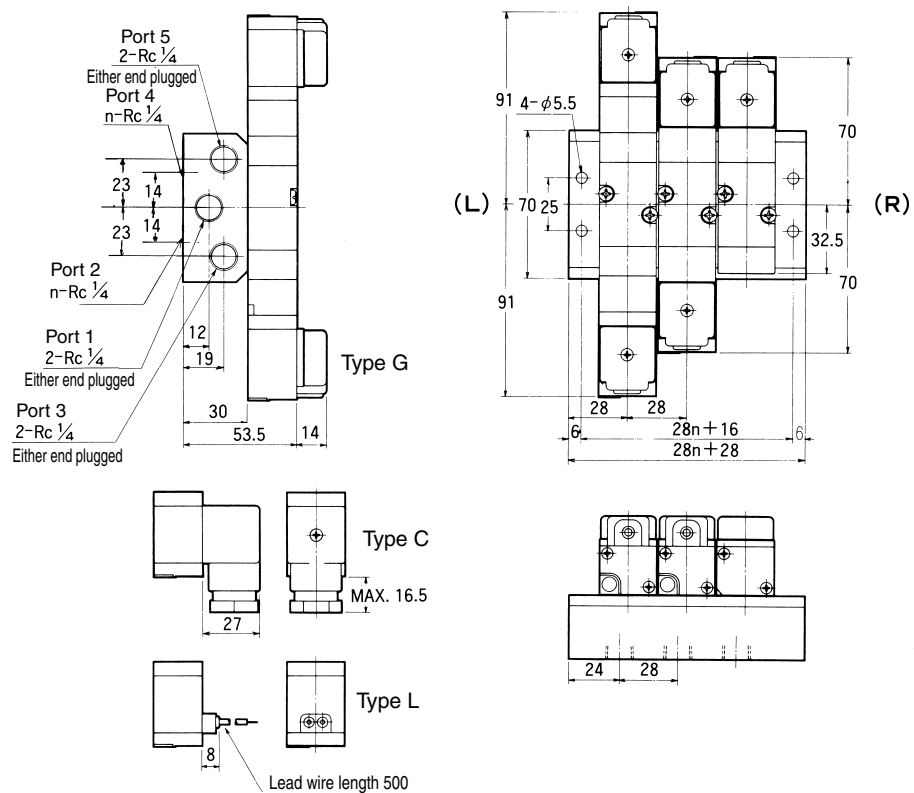

5-PORT PILOT OPERATED SOLENOID VALVES

PC08 Series

Rubber Seal, Sub-base Mounting type

PCS2408	2-position Single solenoid
PCD2408	2-position Double solenoid
PCD3408	3-position Closed center
PCE3408	3-position Exhaust center
PCO3408	3-position Pressure center



SPECIFICATIONS

Model No.	Unit	PCS2408	PCD2408	PCD3408 PCE3408	PCO3408
Fluid		Non-lubricated/lubricated air			
Port size		Ports 1, 2 & 4 : Rc $\frac{3}{8}$		Ports 3 & 5 : Rc $\frac{1}{4}$	
Effective area	mm ²	30		25	14
Cv value		1.63		1.36	0.76
Operating ambient temperature		- 5 ~ 50			
Operating pressure range	MPa	0.2 ~ 0.8			
Maximum frequency	Cycle/min	180			
Response time at 0.5MPa	s	ON 0.035 OFF 0.045	ON 0.02	ON 0.025 OFF 0.035	
Rated voltage	V	AC100/110, 200/220, DC24			
Grade of insulation		JIS grade B			
Permissible voltage fluctuation	%	AC ± 10 , DC $\begin{smallmatrix} +10 \\ -15 \end{smallmatrix}$			
Rated frequency	Hz	50/60			
Power consumption	AC	Holding	50Hz	VA (100/200) 3.2	
			60Hz	VA (100/200) 2.6	
		Inrush	50Hz	VA (100/200) 5	
			60Hz	VA (100/200) 4.5	
Power consumption DC	W	2			
Wiring		Lead wire, Grommet with terminal, Conduit with terminal, DIN connector			
Mass	kg	0.35	0.42	0.58	0.58

(Note) · When temperature of valve site goes down below 5 °C, complete dry air shall be supplied to prevent from freezing.
 · Effective area shown above is value between ports 1 and 2, 4.
 · Response time shown above is in accordance with JIS B 8375.

PC08 Series

ORDERING INSTRUCTION

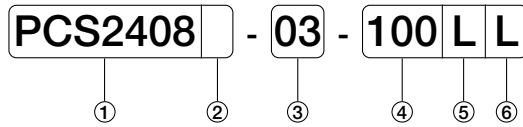

① Model No.

PCS2408	
PCD2408	
PCD3408	
PCE3408	
PCO3408	

⑤ Wiring

L	Lead wire
G	Grommet with terminal
C	Conduit with terminal
GK	Grommet with surge suppressor
CK	Conduit with surge suppressor
D	DIN connector

⑥ Manual override

No mark	Standard (None locking)
L	With locking button

: Made to order

② Special specifications

No mark	Standard (Internal pilot)
X	External pilot (Pilot port on sub-base)

③ Port size

03	Rc ³ / ₈
NB	Without sub-base

④ Voltage

100	AC100/110V
200	AC200/220V
D24	DC24V

CONSTRUCTION

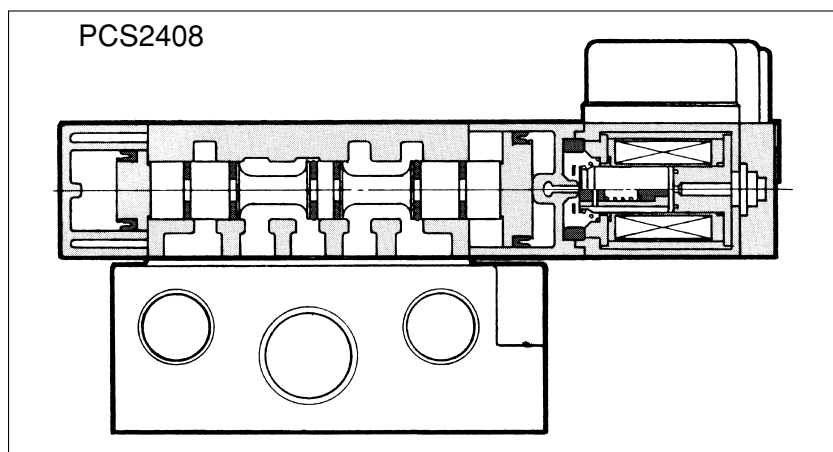

SPARE PARTS

Sub-base

Port size	Model No.
Rc ³ / ₈	PC08-SB-03
Rc ³ / ₈ (For external pilot)	PC08-SB-X03

DIMENSIONS

PCS2408

(Unit : mm)

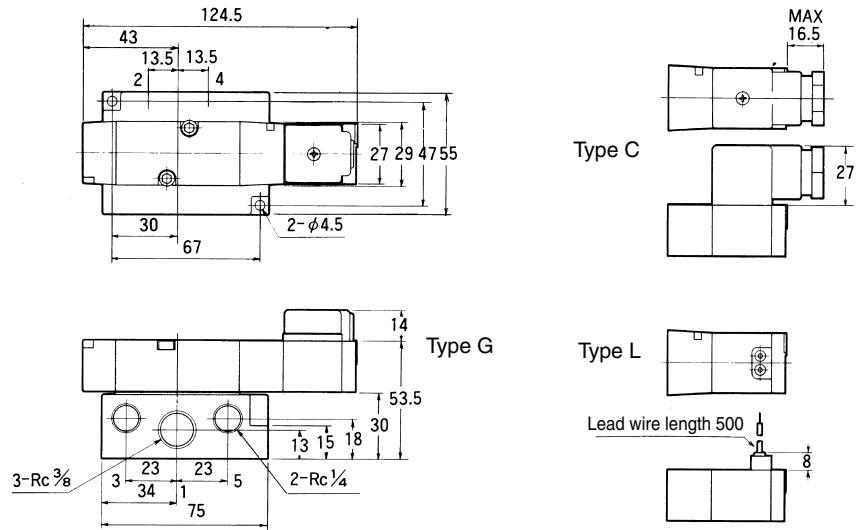

PCD2408

(Unit : mm)

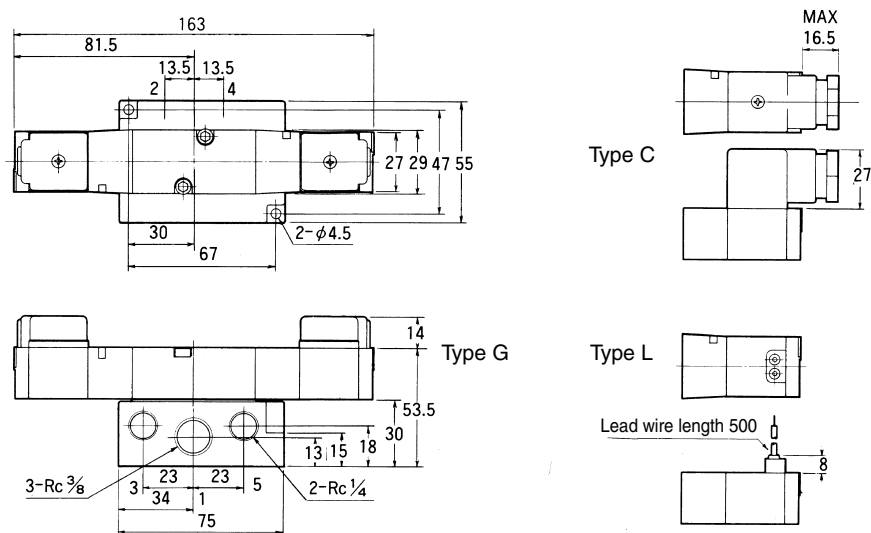

PC08 Series

DIMENSIONS

PCD3408、PCE3408、PCO3408

(Unit : mm)

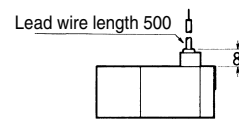
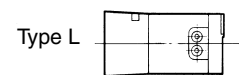
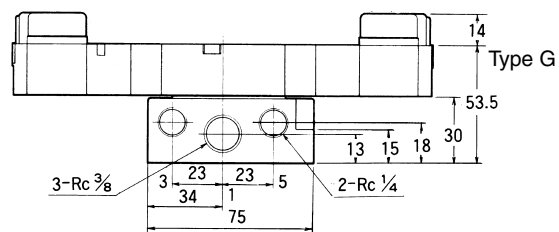
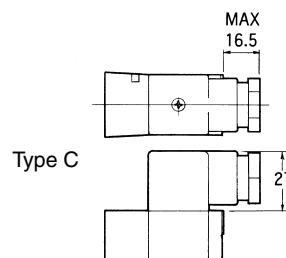
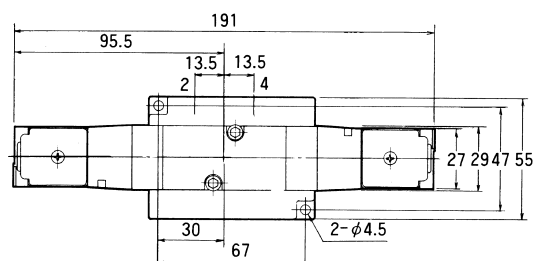

INDIVIDUAL WIRING TYPE MANIFOLD

MF -PC08

Separate type/Bar type

MF -PC08 Common SUP, Common EXH
Separate type Ports 2 & 4 on both sides

MFS -PC08 Common SUP, Common EXH
Bar type Ports 2 & 4 on side

Available for multipurpose

As pilot air supply is branched in manifold, it can be used for special purposes such as double supply, low pressure, vacuum, etc. (Refer to Page 10)

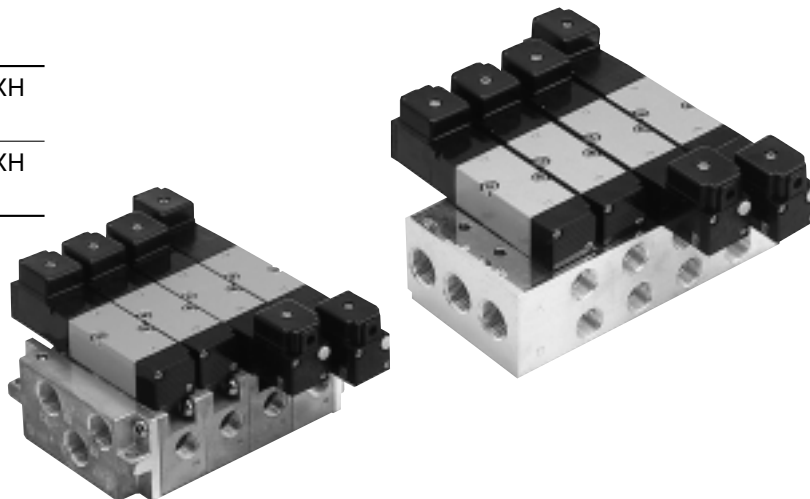

MANIFOLD SPECIFICATIONS

Type of manifold		MF -PC08 Common SUP, common EXH Ports 2 & 4 on both sides	MFS -PC08 Common SUP, common EXH Ports 2 & 4 on side
Port size	Port 1	Rc $\frac{1}{2}$ (Both sides)	Rc $\frac{1}{2}$ (Both sides)
	Port 3, 5	Rc $\frac{1}{2}$ (Both sides)	Rc $\frac{1}{2}$ (Both sides)
	Port 2, 4	Rc $\frac{3}{8}$ (Both sides)	Rc $\frac{3}{8}$ (Side)
Number of stations		2 ~ 10	
Mountable solenoid valve		PCS2408-NB- PCD2408-NB- PCD3408-NB- PCE3408-NB- PCO3408-NB-	
Blank plate		PC08-BP	

HOW TO ORDER

Specify the type and quantity of Manifold and Solenoid Valve to be mounted, and the quantity of Blank Plate (PC08-BP) in accordance with the following example of description.

(Example) **MFS8-PC08-03**

PCS2408-NB-100G	4 pcs.
PCD2408-NB-100G	2 pcs.
PCD3408-NB-100G	1 pc.
PC08-BP	1 pc.

Parts of Separate type Manifold

Parts Name	Parts No.
End block set	MF-PC08-MB
Manifold block	MF-PC08-BD

(Note) Mounting screws & O-ring are supplied



CAUTION

When mounting a solenoid valve to be used at different pressure on the same manifold, mount a solenoid valve intended to be used by supplying the highest pressure (0.8MPa maximum) from port 1 on one of the right end or left end.

Manifold of MF -PC08 used a coupling method for single-station type manifold.

For special circuits, use " Specification for Manifold " .

PC08 Series

ORDERING INSTRUCTION

Manifold

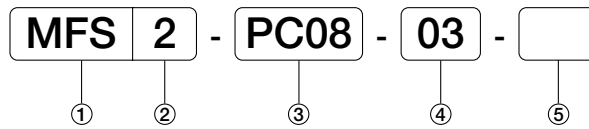

① Type of manifold

MF	Separate type Common SUP, common EXH Ports 2 & 4 on both sides
MFS	Bar type Common SUP, Common EXH Ports 2 & 4 on side

② Number of stations

2	2 station
⋮	⋮
10	10station

③ Mountable solenoid valve

PC08	PC08 series
------	-------------

④ Size of ports 2 and 4

03	Rc $\frac{3}{8}$
----	------------------

⑤ Special specifications

No mark	Standard
A	Bottom ported

(Note) A : MF only

Mountable solenoid valve (For details refer to Pages 18 to 21.)

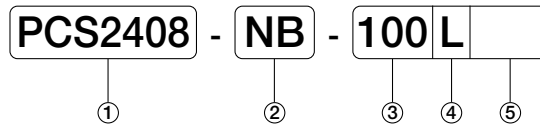

① Model No.

PCS2408	
PCD2408	
PCD3408	
PCE3408	
PCO3408	

④ Wiring

L	Lead wire
G	Grommet with terminal
C	Conduit with terminal
GK	Grommet with surge suppressor
CK	Conduit with surge suppressor
D	DIN connector

⑤ Manual override

No mark	Standard (None locking)
L	With locking button

: Made to order

② Port size

NB	Without sub-base
----	------------------

③ Voltage

100	AC100/110V
200	AC200/220V
D24	DC24V

DIMENSIONS

MF - PC08

(Unit : mm)

(Note) Standard manifold is plugged on " R " (Right) side ports.

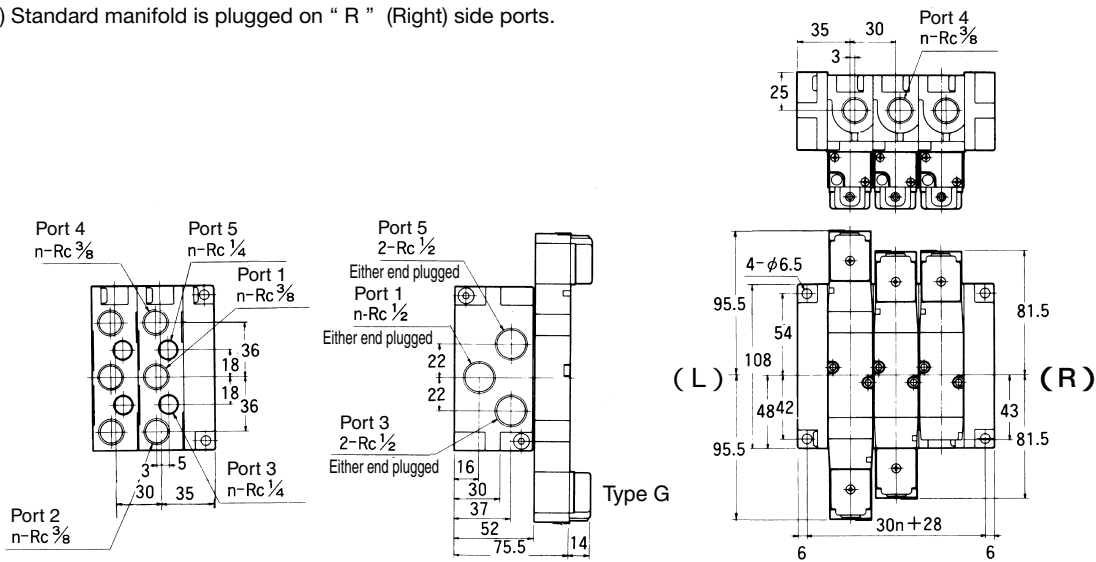

**Bottom ported
(Special specification)**



MFS - PC08

(Unit : mm)

(Note) Standard manifold is plugged on " R " (Right) side ports.

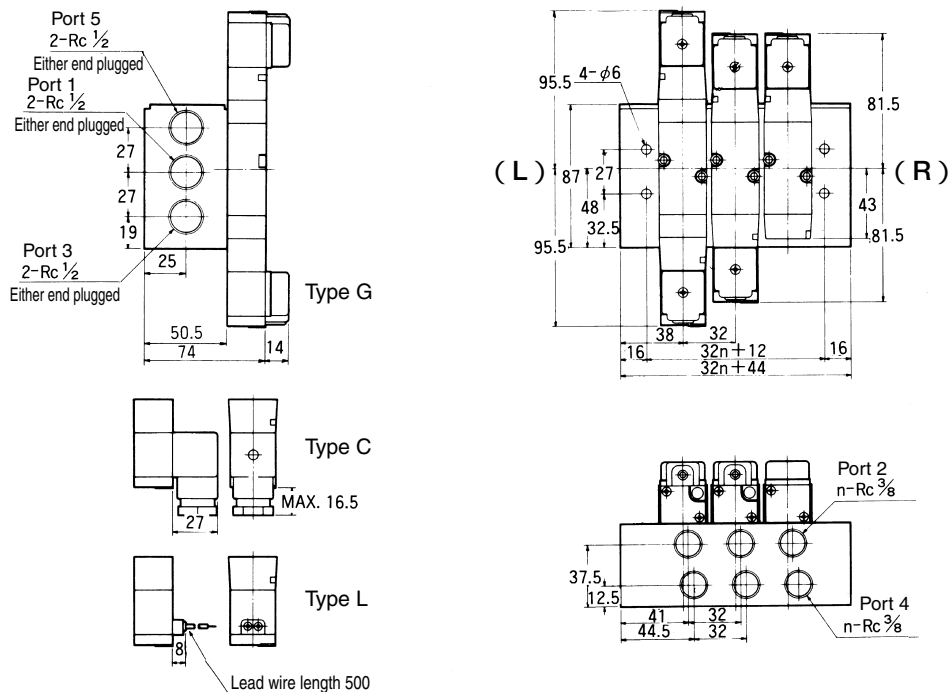

5-PORT PILOT OPERATED SOLENOID VALVES

PC15 Series

Rubber Seal, Sub-base Mounting type

PCS2415 2-position
Single solenoid

PCD2415 2-position
Double solenoid

PCD3415 3-position
Closed center

PCE3415 3-position
Exhaust center

PCO3415 3-position
Pressure center

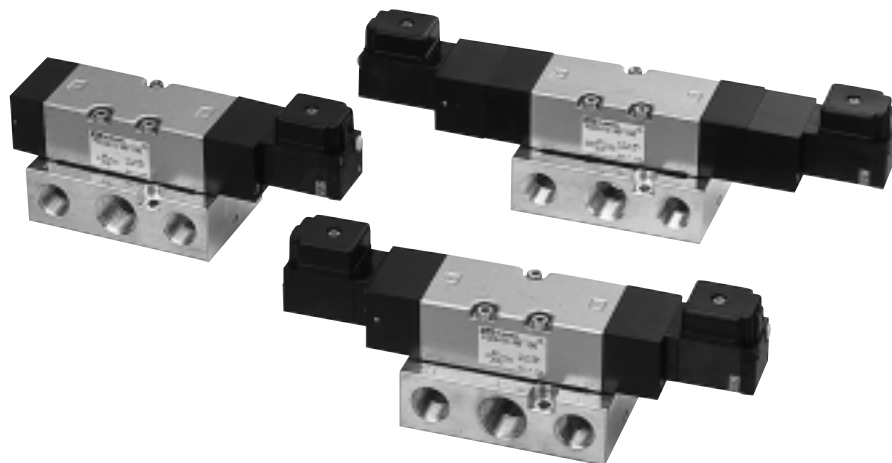

SPECIFICATIONS

Model No.	Unit	PCS2415	PCD2415	PCD3415 PCE3415	PCO3415
Fluid		Non-lubricated/lubricated air			
Port size		Ports 1, 2 & 4 : Rc $\frac{1}{2}$		Ports 3 & 5 : Rc $\frac{3}{8}$	
Effective area	mm ²	70		60	
Cv value		3.80		3.25	
Operating ambient temperature		- 5 ~ 50			
Operating pressure range	MPa	0.2 ~ 0.8		0.25 ~ 0.8	
Maximum frequency	Cycle/min	120			
Response time at 0.5MPa	s	ON 0.035 OFF 0.060		ON 0.02	ON 0.025 OFF 0.110
Rated voltage	V	AC100/110, 200/220, DC24			
Grade of insulation		JIS grade B			
Permissible voltage fluctuation	%	AC ± 10 , DC $\pm \frac{10}{15}$			
Rated frequency	Hz	50/60			
Power consumption	AC	Holding	50Hz	VA (100/200) 3.2	
			60Hz	VA (100/200) 2.6	
		Inlush	50Hz	VA (100/200) 5	
			60Hz	VA (100/200) 4.5	
Power consumption DC	W	2			
Wiring		Lead wire, Grommet with terminal, Conduit with terminal, DIN connector			
Mass	kg	0.73	0.81	0.94	0.94

(Note) • When temperature of valve site goes down below 5 , complete dry air shall be supplied to prevent from freezing.
 • Effective area shown above is value between ports 1 and 2, 4.
 • Response time shown above is in accordance with JIS B 8375.

ORDERING INSTRUCTION

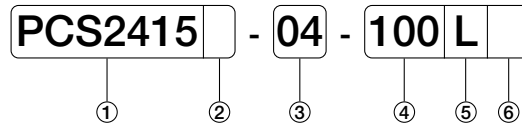

① Model No.

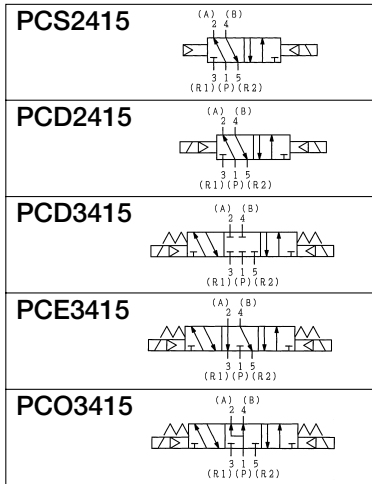

⑤ Wiring

L	Lead wire
G	Grommet with terminal
C	Conduit with terminal
GK	Grommet with surge suppressor
CK	Conduit with surge suppressor
D	DIN connector

⑥ Manual override

No mark	Standard (None locking)
L	With locking button

: Made to order

② Special specifications

No mark	Standard (Internal pilot)
X	External pilot (Pilot port on sub-base)

③ Port size

04	Rc 1/2
NB	Without sub-base

④ Voltage

100	AC100/110V
200	AC200/220V
D24	DC24V

CONSTRUCTION

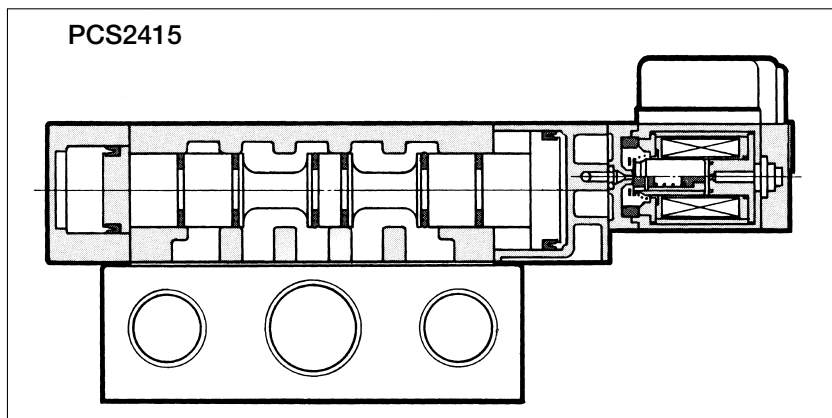

SPARE PARTS

Sub-base

Port size	Model No.
RcRc 1/2	PC15-SB-04
Rc 1/2 (For external pilot)	PC15-SB-X04

PC15 Series

DIMENSIONS

PCS2415

(Unit : mm)

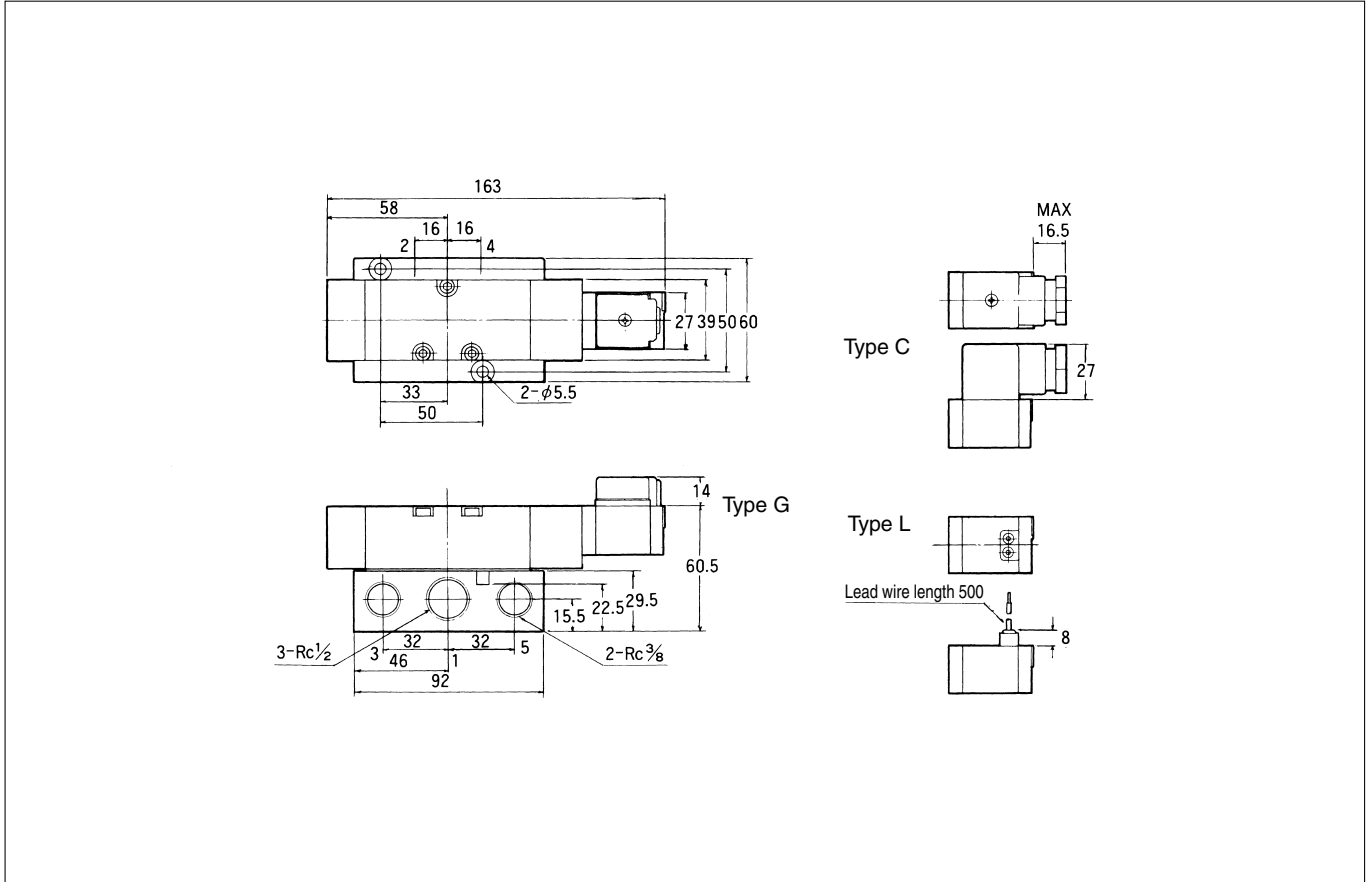

PCD2415

(Unit : mm)

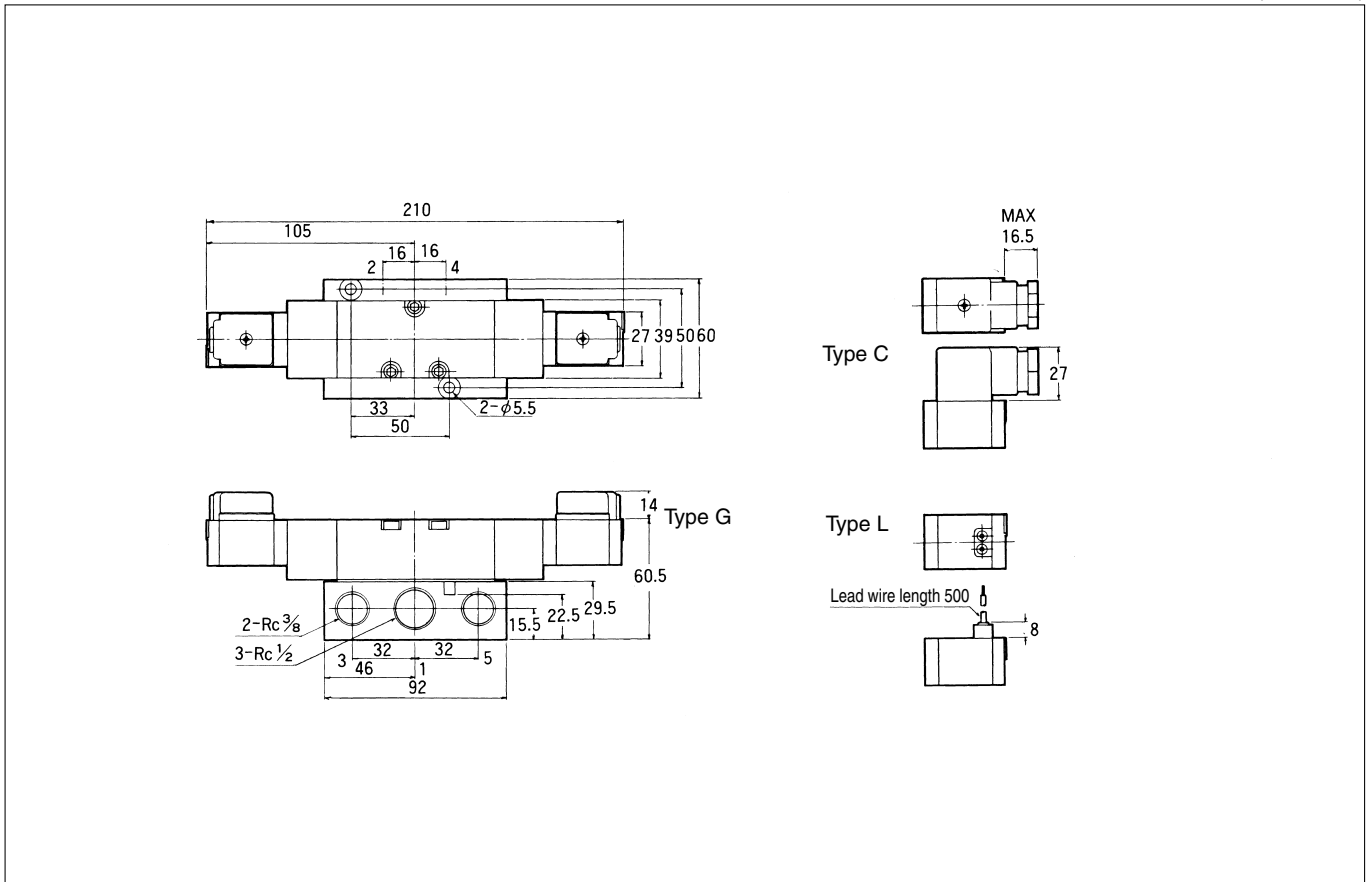

DIMENSIONS

PCD3415、PCE3415、PCO3415

(Unit : mm)

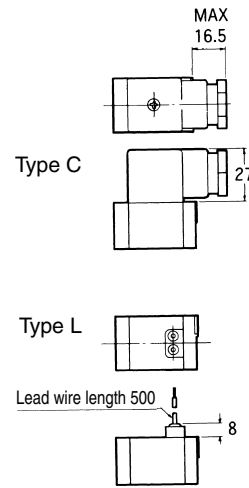
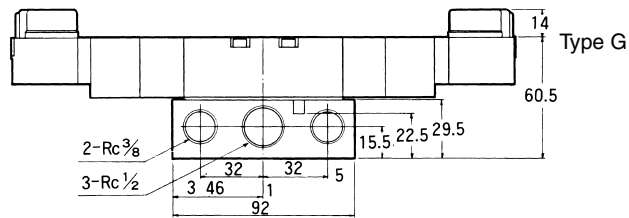
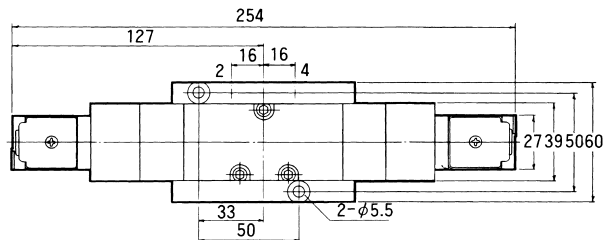

INDIVIDUAL WIRING TYPE MANIFOLD

MF -PC15

Bar type

MF -PC15 Common SUP, Common EXH
Ports 2 & 4 on both sides

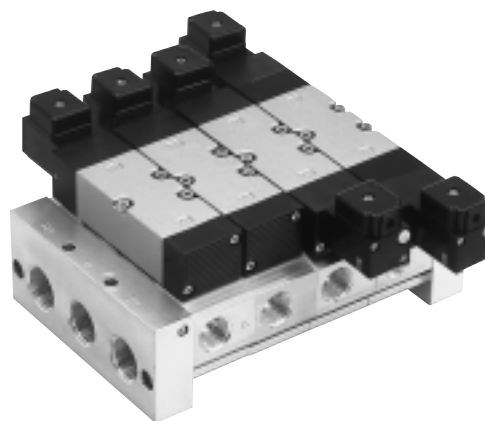

Available for multipurpose

As pilot air supply is branched in manifold, it can be used for special purpose such as double supply, low pressure, vacuum, etc. (Refer to Page 10.)

MANIFOLD SPECIFICATIONS

Type of manifold		MF -PC15 Common SUP, common EXH Ports 2 & 4 on both sides
Port size	Port 1	Rc ³ / ₄ (Both sides)
	Port 3, 5	Rc ³ / ₄ (Both sides)
	Port 2, 4	Rc ¹ / ₂ (Both sides)
Number of stations		2 ~ 10
Mountable solenoid valve		PCS2415-NB- PCD2415-NB- PCD3415-NB- PCE3415-NB- PCO3415-NB-
Blank plate		PC15-BP

HOW TO ORDER

Specify the type and quantity of Manifold and Solenoid valve to be mounted, and the quantity of Blank Plate (PC08-BP) in accordance with the following example of description.

(Example) **MF8-PC15-04**

PCS2415-NB-100G	4pcs.
PCD2415-NB-100G	2pcs.
PCD3415-NB-100G	1pc.
PC15-BP	1pc.

Parts of Separate type Manifold

Parts Name	Parts No.
End block set	MF-PC15-MB
Manifold block	MF1-PC15-BD

(Note) Mounting screws & O-ring are supplied



CAUTION

When mounting a solenoid valve to be used at different pressure on the same manifold, mount a solenoid valve intended to be used by supplying the highest pressure (0.8MPa maximum) from port 1 on one of the right end or left end.

For special circuits, use " Specification for Manifold ".

ORDERING INSTRUCTION

Manifold

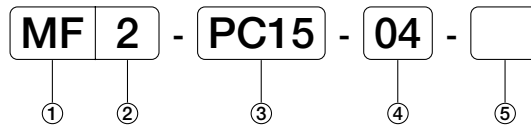

① Type of manifold

MF	Common SUP, common EXH Ports 2 & 4 on both sides
----	---

③ Mountable solenoid valve

PC15	PC15 series
------	-------------

② Number of stations

2	2 station
⋮	⋮
10	10station

④ Size of ports 2 and 4

04	Rc ¹ / ₂
----	--------------------------------

⑤ Special specifications

No mark	Standard
A	Bottom ported

Mountable solenoid valve (For details refer to Pages 25 to 28.)

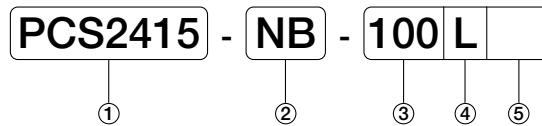

① Model No.

PCS2415	
PCD2415	
PCD3415	
PCE3415	
PCO3415	

④ Wiring

L	Lead wire
G	Grommet with terminal
C	Conduit with terminal
GK	Grommet with surge suppressor
CK	Conduit with surge suppressor
D	DIN connector

⑤ Manual override

No mark	Standard (None locking)
L	With locking button

: Made to order

② Port size

NB	Without sub-base
----	------------------

③ Voltage

100	AC100/110V
200	AC200/220V
D24	DC24V

PC15 Series

DIMENSIONS

MF -PC15

(Unit : mm)

(Note) Standard manifold is plugged on " R " (Right) side ports.

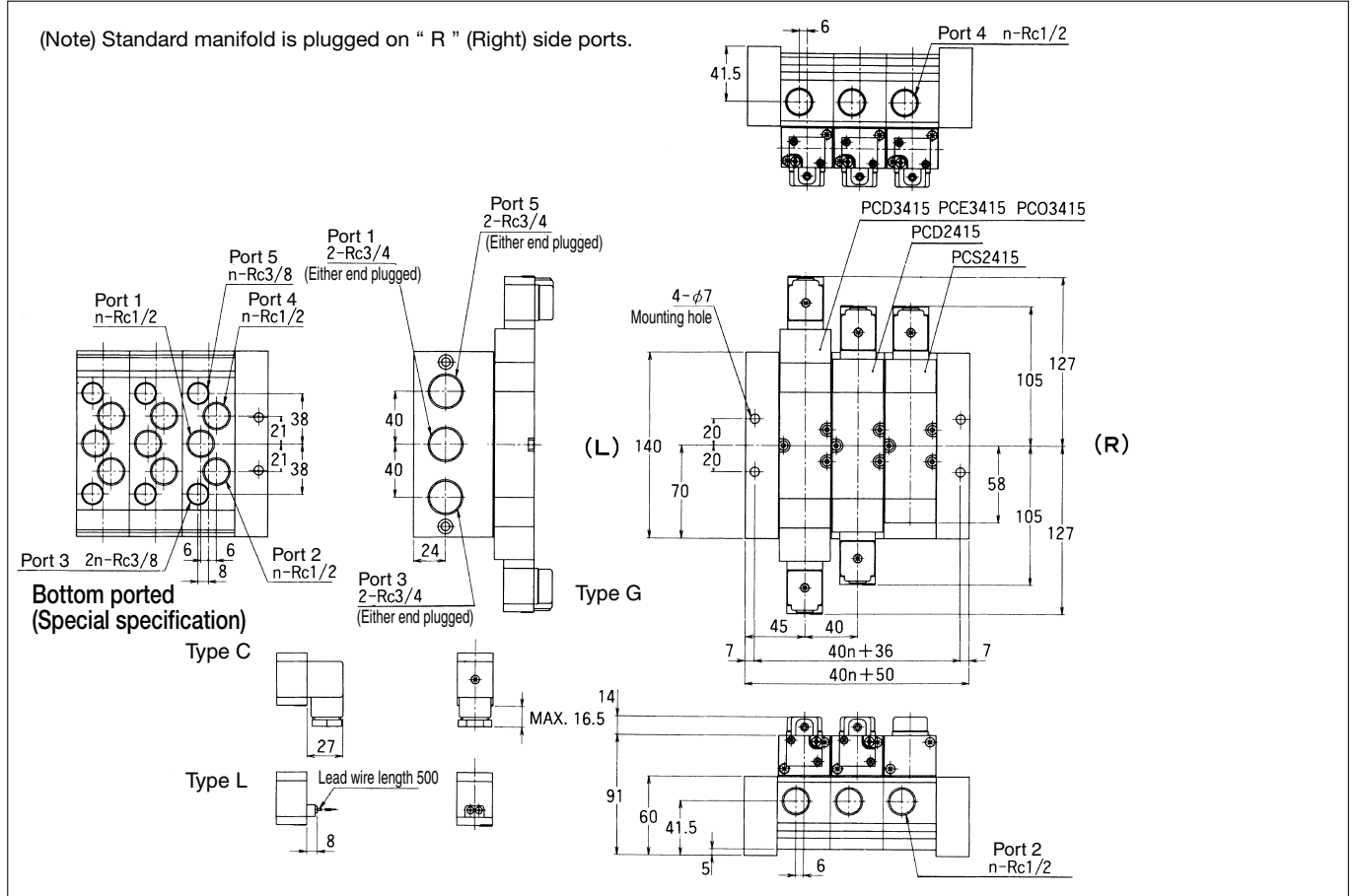

5-PORT PILOT OPERATED SOLENOID VALVES

RC06 Series

Rubber Seal, In-line Mounting type

RCS2406	2-position Single solenoid
RCD2406	2-position Double solenoid
RCD3406	3-position Closed center
RCE3406	3-position Exhaust center
RCO3406	3-position Pressure center



SPECIFICATIONS

Model No.		Unit	RCS2406	RCD2406	RCD3406 RCE3406	RCO3406
Fluid			Non-lubricated/lubricated air			
Port size			Ports 1, 2 & 4 : Rc $\frac{1}{4}$		Ports 3 & 5 : Rc $\frac{1}{8}$	
Effective area		mm ²	12		11	
Cv value			0.65		0.60	
Operating ambient temperature			- 5 ~ 50			
Operating pressure range		MPa	0.2 ~ 0.8			
Maximum frequency		Cycle/min	240		180	
Response time at 0.5MPa		s	ON 0.021 OFF 0.021	ON 0.015	ON 0.025 OFF 0.035	
Rated voltage		V	AC100/110、200/220、DC24			
Grade of insulation			JIS grade B			
Permissible voltage fluctuation		%	AC ± 10 、DC $\begin{matrix} +10 \\ -15 \end{matrix}$			
Rated frequency		Hz	50/60			
Power consumption	AC	Holding	50Hz	VA	(100/200) 3.2	
			60Hz	VA	(100/200) 2.6	
	Inlush	50Hz	VA	(100/200) 5		
		60Hz	VA	(100/200) 4.5		
Power consumption DC		W	2			
Wiring			Lead wire, Grommet with terminal, Conduit with terminal, DIN connector			
Mass		kg	0.14	0.21	0.3	0.3

(Note) · When temperature of valve site goes down below 5 °C, complete dry air shall be supplied to prevent from freezing.
 · Effective area shown above is value between ports 1 and 2, 4.
 · Response time shown above is in accordance with JIS B 8375.

RC06 Series

ORDERING INSTRUCTION

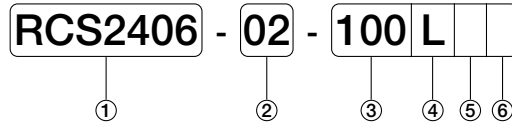

① Model No.

RCS2406	
RCD2406	
RCD3406	
RCE3406	
RCO3406	

④ Wiring

L	Lead wire
G	Grommet with terminal
C	Conduit with terminal
GK	Grommet with surge suppressor
CK	Conduit with surge suppressor
D	DIN connector

⑤ Manual override

No mark	Standard (None locking)
L	With locking button

⑥ Special specifications

No mark	Standard
B	With mounting bracket

② Port size

02	Rc ¹ / ₄
----	--------------------------------

: Made to order

③ Voltage

100	AC100/110V
200	AC200/220V
D24	DC24V

CONSTRUCTION

RCS2406

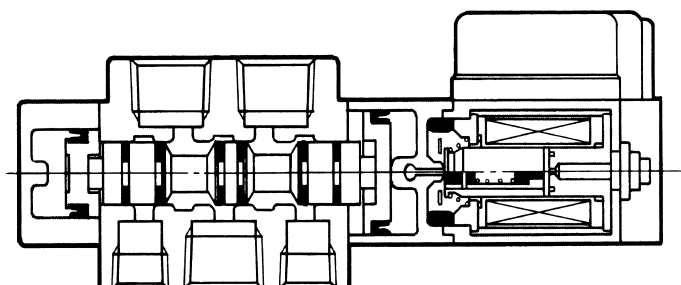

DIMENSIONS

RCS2406

(Unit : mm)

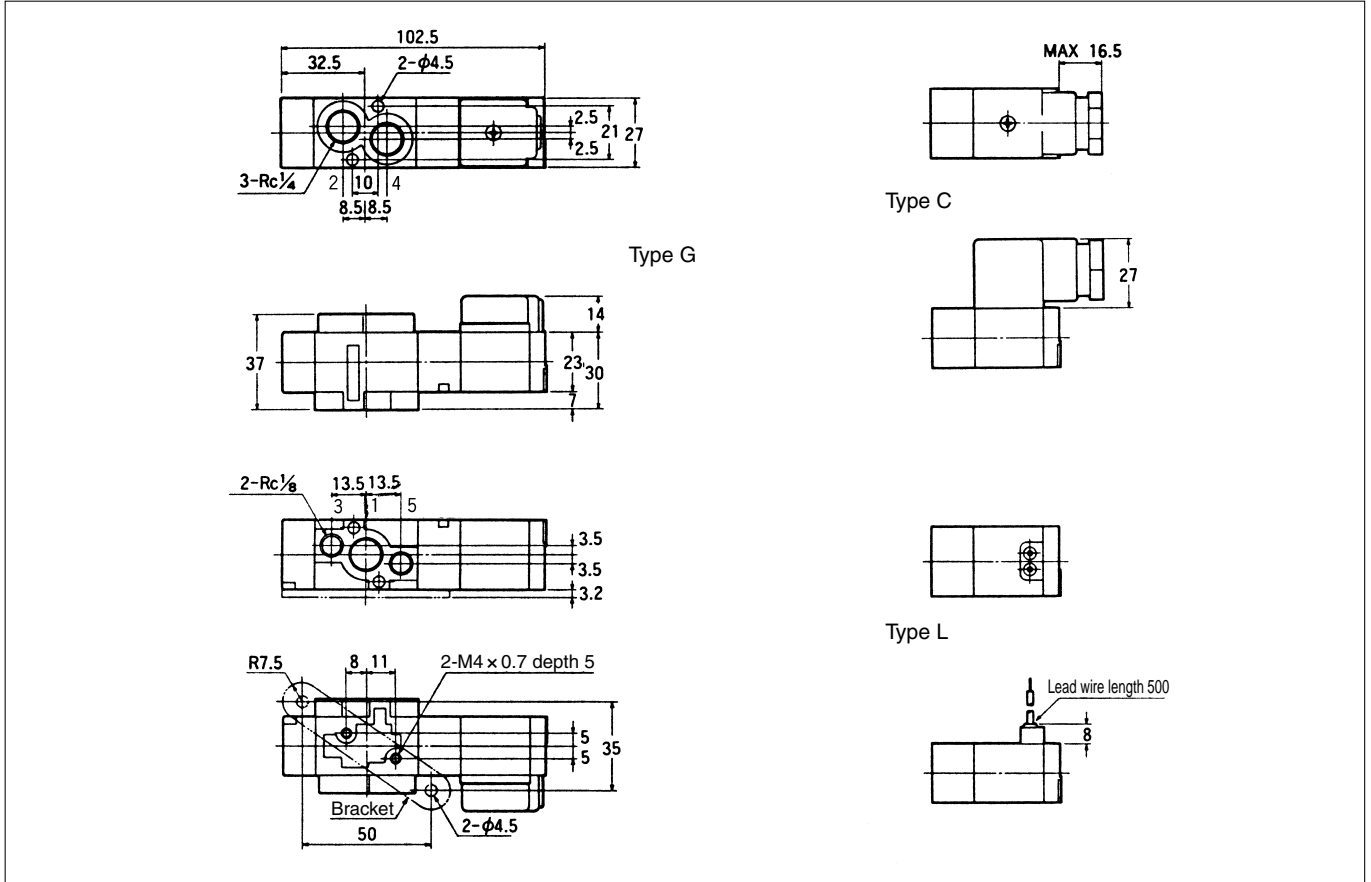

RCD2406

(Unit : mm)

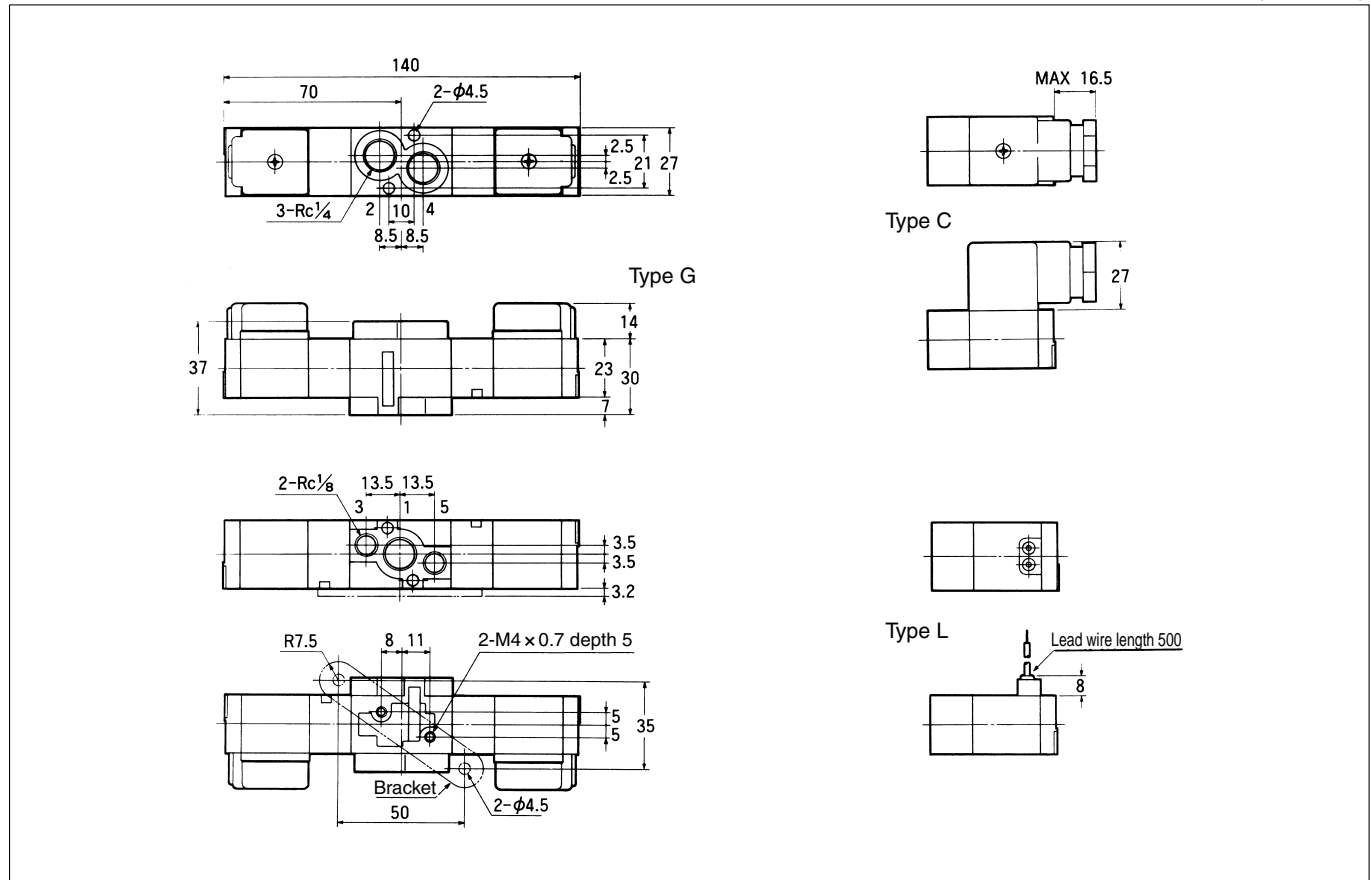

RC06 Series

DIMENSIONS

RCD3406, RCE3406, RCO3406

(Unit : mm)

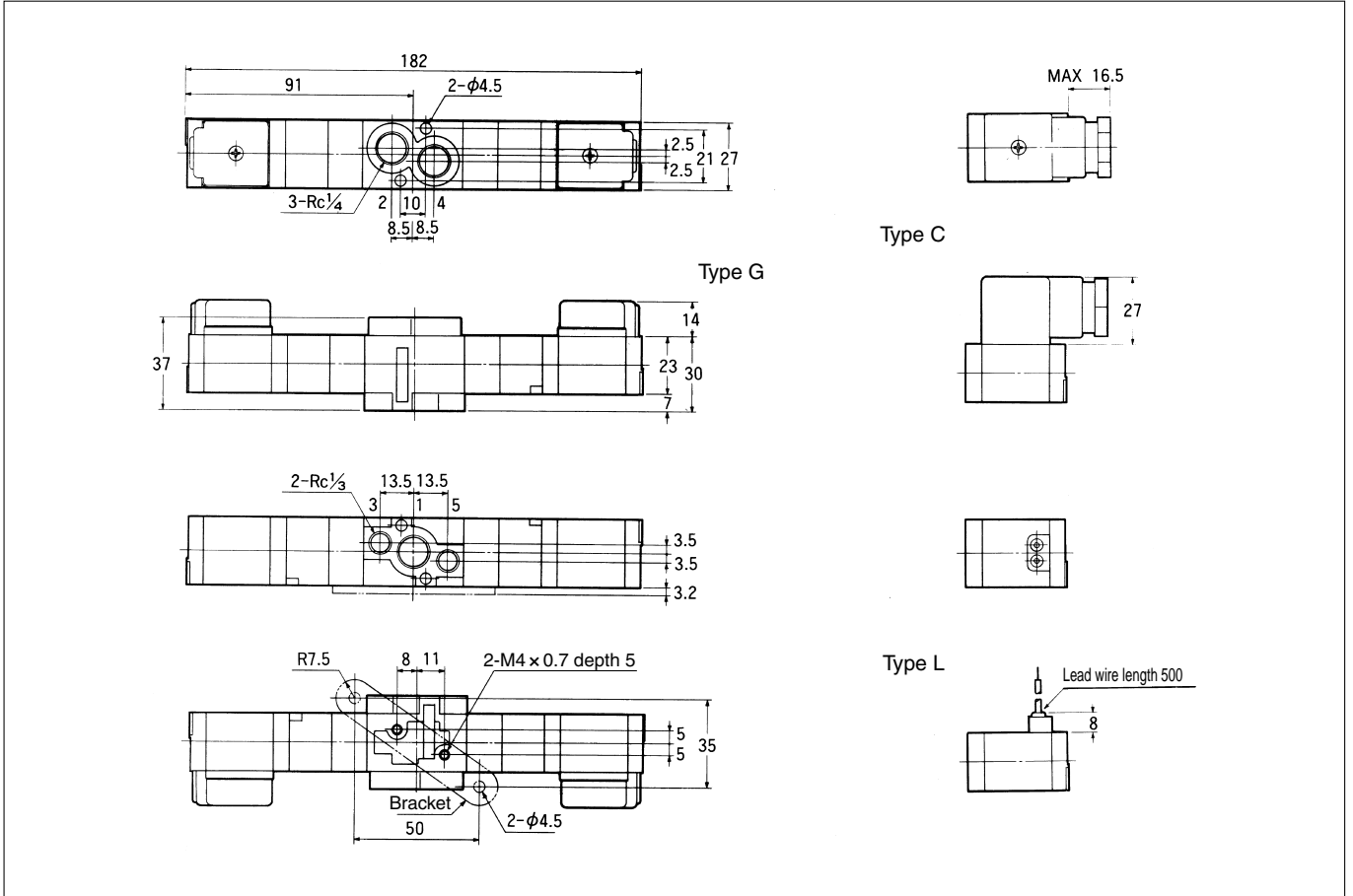

INDIVIDUAL WIRING TYPE MANIFOLD

MF -RC06

Bar type

MFU -RC06 Common SUP, Common EXH
Ports 2 & 4 on valve body

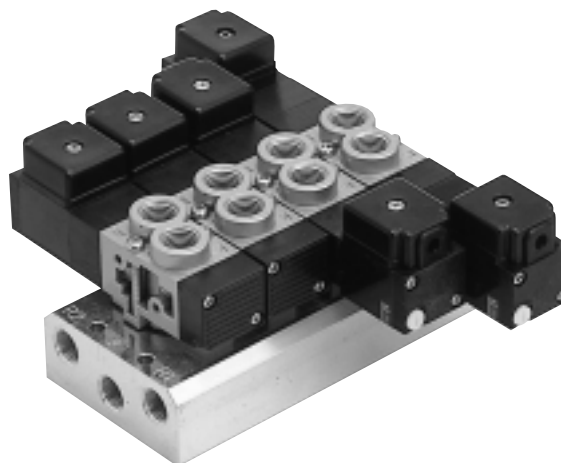

MANIFOLD SPECIFICATIONS

Type of manifold	MFU -RC06 Common SUP, common EXH Ports 2 & 4 on valve body	
Port size	Port 1	Rc $\frac{1}{4}$ (Both sides)
	Port 3, 5	Rc $\frac{1}{4}$ (Both sides)
	Port 2, 4	Rc $\frac{1}{4}$ (Valve body)
Number of stations	2 ~ 10	
Mountable solenoid valve	RCS2406- - -MF RCD2406- - -MF RCD3406- - -MF RCE3406- - -MF RCO3406- - -MF	
Blank plate	RC06-BP	

HOW TO ORDER

Specify the type and quantity of Manifold and Solenoid Valve to be mounted, and the quantity of Blank Plate (RC06-BP) in accordance with the following example of description.

(Example) **MFU8-RC06-02**

RCS2406-02-100G-MF	4 pcs.
RCD2406-02-100G-MF	2 pcs.
RCD3406-02-100G-MF	1 pc.
RC06-BP	1 pc.

RC06 Series

ORDERING INSTRUCTION

Manifold

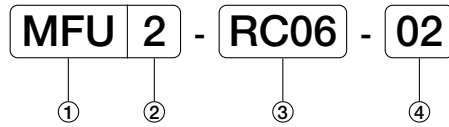

① Type of manifold

MFU	Common SUP, common EXH Ports 2 & 4 on valve body
-----	---

③ Mountable solenoid valve

RC06	RC06 series
------	-------------

② Number of stations

2	2 station
⋮	⋮
10	10 station

④ Size of ports 2 and 4

02	Rc $\frac{1}{4}$
----	------------------

Mountable solenoid valve (For details refer to Pages 32 to 35.)

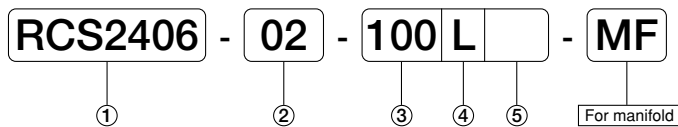

① Model No.

RCS2406	
RCD2406	
RCD3406	
RCE3406	
RCO3406	

④ Wiring

L	Lead wire
G	Grommet with terminal
C	Conduit with terminal
GK	Grommet with surge suppressor
CK	Conduit with surge suppressor
D	DIN connector

⑤ Manual override

No mark	Standard (None locking)
L	With locking button

: Made to order

② Port size

02	Rc $\frac{1}{4}$
----	------------------

③ Voltage

100	AC100/110V
200	AC200/220V
D24	DC24V

DIMENSIONS

MFU -RC06-02

(Unit : mm)

(Note) Standard manifold is plugged on " R " (Right) side ports.

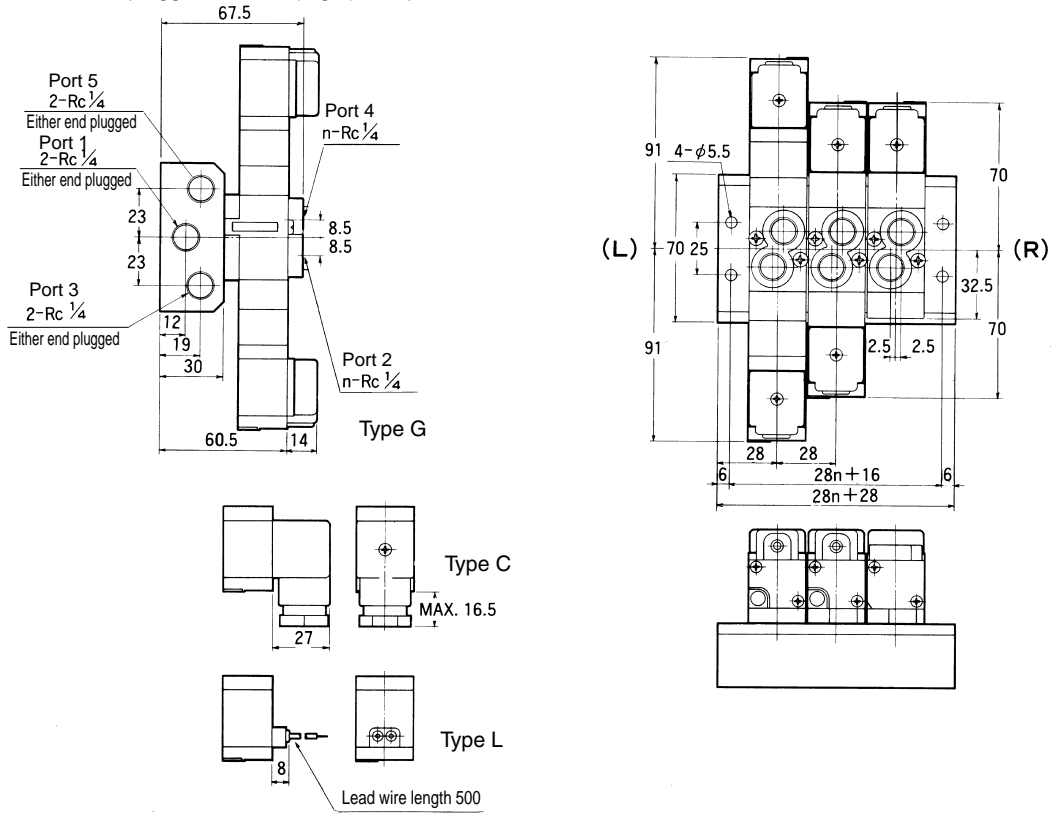

5-PORT PILOT OPERATED SOLENOID VALVES

RC08 Series

Rubber Seal, In-line Mounting type

PCS2408 2-position
Single solenoid

RCD2408 2-position
Double solenoid

RCD3408 3-position
Closed center

RCE3408 3-position
Exhaust center

RCO3408 3-position
Pressure center

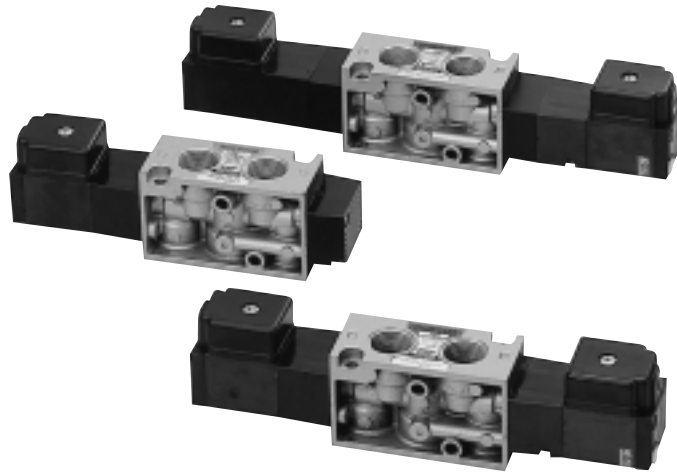

SPECIFICATIONS

Model No.	Unit	RCS2408	RCD2408	RCD3408 RCE3408	RCO3408
Fluid		Non-lubricated/lubricated air			
Port size		Ports 1, 2 & 4 : Rc ³ / ₈		Ports 3 & 5 : Rc ¹ / ₄	
Effective area	mm ²	30		25	14
Cv value		1.63		1.36	0.76
Operating ambient temperature		-5 ~ 50			
Operating pressure range	MPa	0.2 ~ 0.8			
Maximum frequency	Cycle/min	180			
Response time at 0.5MPa	s	ON 0.035 OFF 0.045	ON 0.02	ON 0.025 OFF 0.035	
Rated voltage	V	AC100/110, 200/220, DC24			
Grade of insulation		JIS grade B			
Permissible voltage fluctuation	%	AC ± 10, DC ⁺¹⁰ / ₋₁₅			
Rated frequency	Hz	50/60			
Power consumption	AC	Holding	50Hz	VA (100/200) 3.2	
			60Hz	VA (100/200) 2.6	
		Inlush	50Hz	VA (100/200) 5	
			60Hz	VA (100/200) 4.5	
Power consumption DC	W	2			
Wiring		Lead wire, Grommet with terminal, Conduit with terminal, DIN connector			
Mass	kg	0.16	0.23	0.29	0.29

(Note) • When temperature of valve site goes down below 5 °C, complete dry air shall be supplied to prevent from freezing.
• Effective area shown above is value between ports 1 and 2, 4.
• Response time shown above is in accordance with JIS B 8375.

ORDERING INSTRUCTION

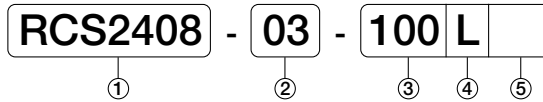

① Model No.

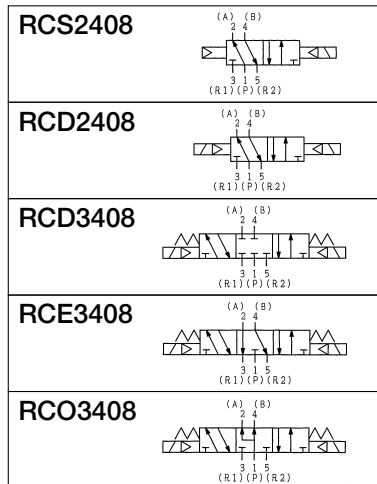

④ Wiring

L	Lead wire
G	Grommet with terminal
C	Conduit with terminal
GK	Grommet with surge suppressor
CK	Conduit with surge suppressor
D	DIN connector

⑤ Manual override

No mark	Standard (None locking)
L	With locking button

: Made to order

② Port size

03	$Rc\frac{3}{8}$
----	-----------------

③ Voltage

100	AC100/110V
200	AC200/220V
D24	DC24V

CONSTRUCTION

RCS2408

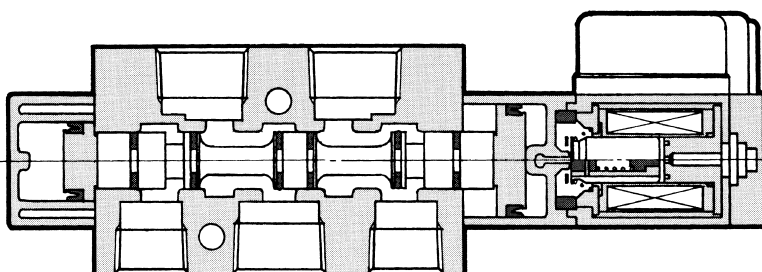

RC08 Series

DIMENSIONS

RCS2408

(Unit : mm)

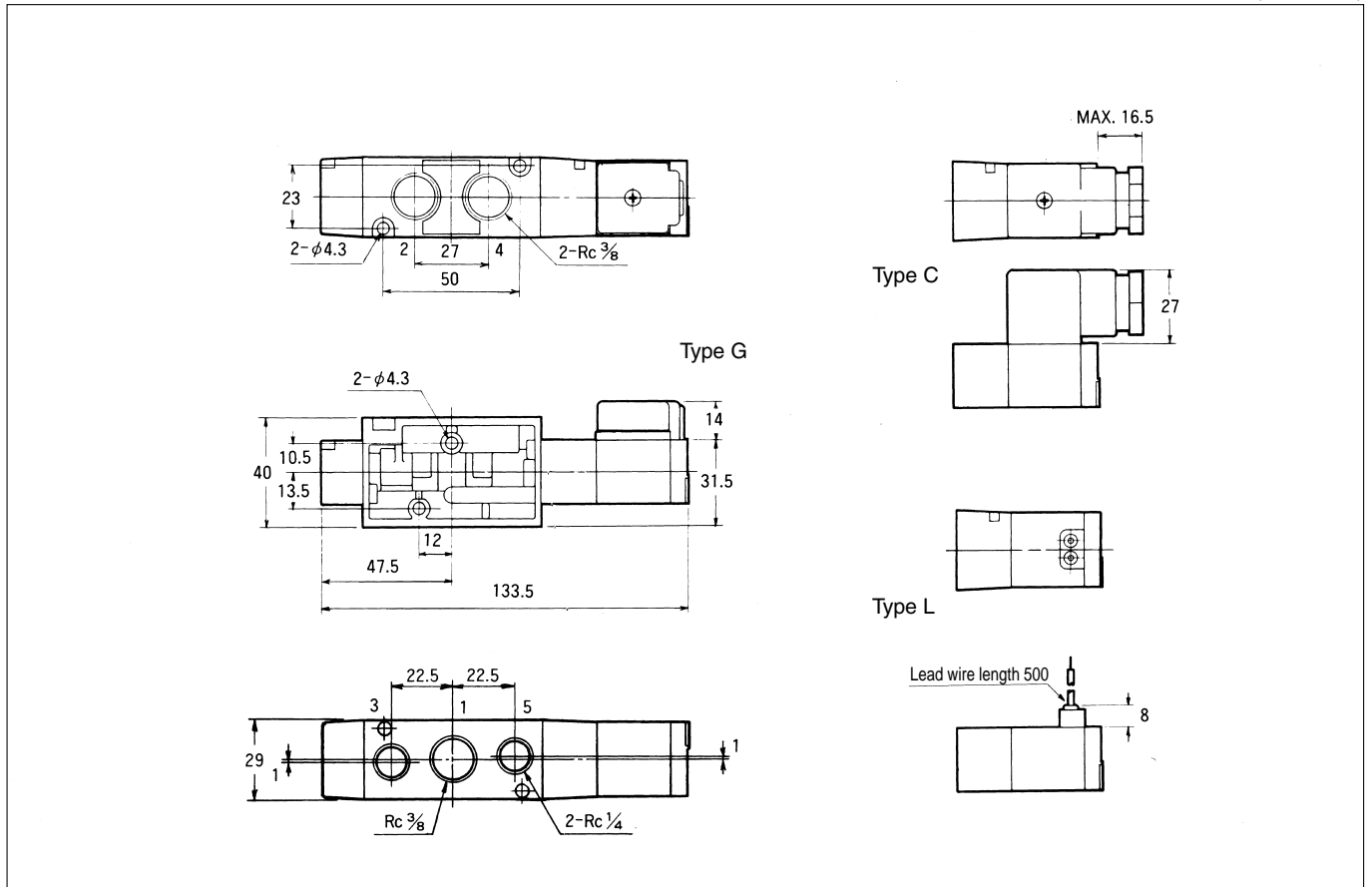

RCD2408

(Unit : mm)

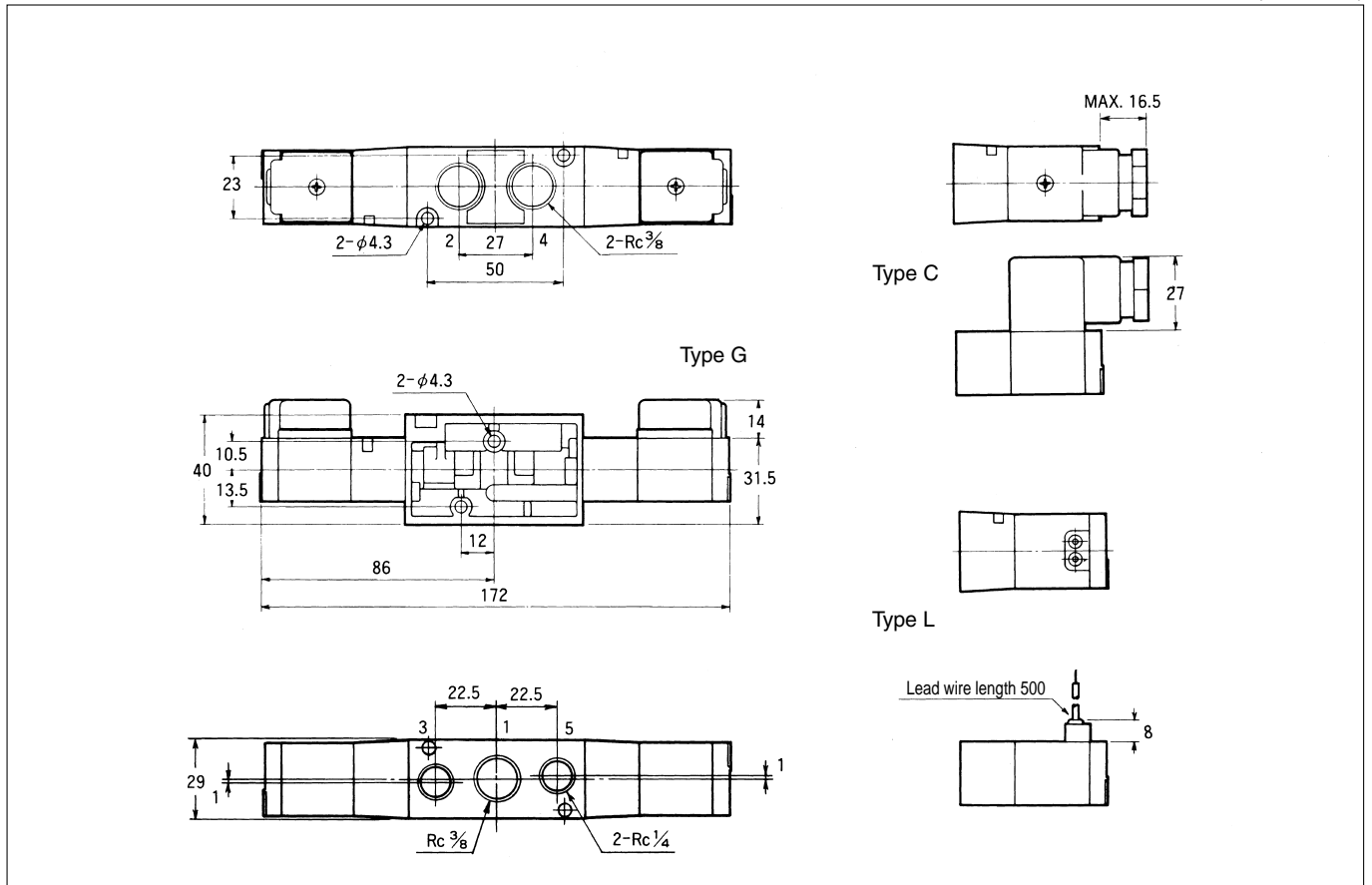

DIMENSIONS

RCD3408, RCE3408, RCO3408

(Unit : mm)

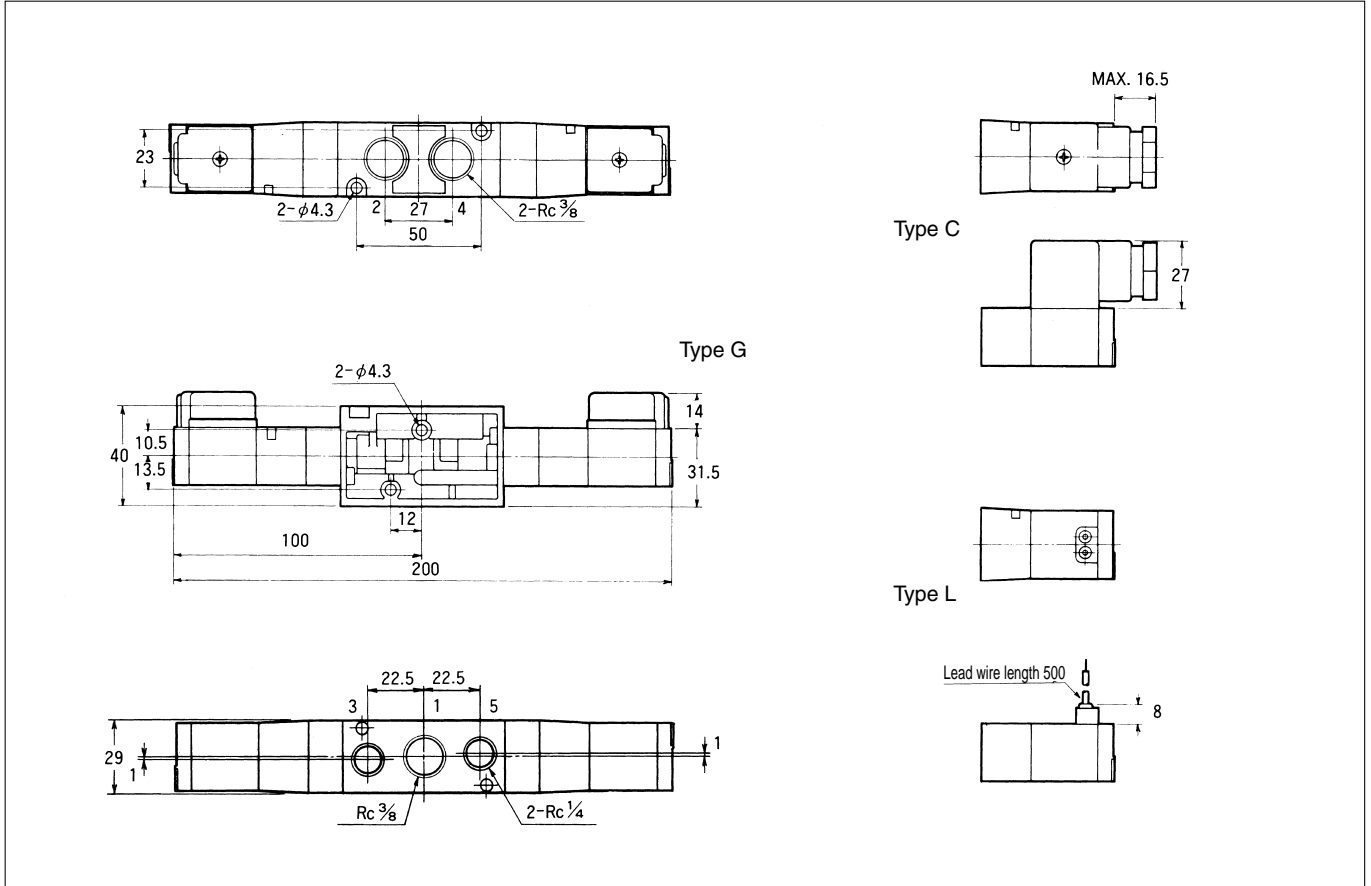

INDIVIDUAL WIRING TYPE MANIFOLD

MF -RC08

Bar type

MFU -RC08 Common SUP, Common EXH
Ports 2 & 4 on valve body

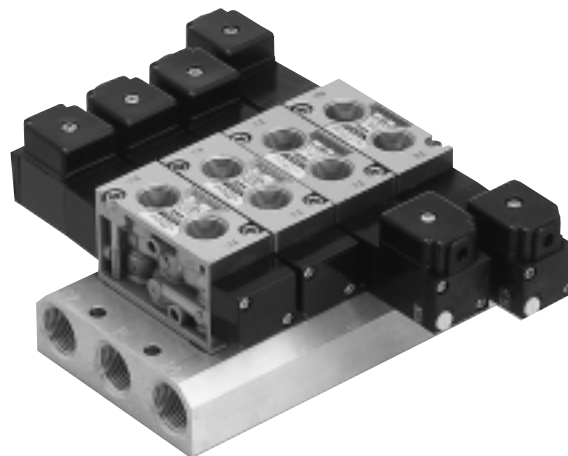

MANIFOLD SPECIFICATIONS

Type of manifold	MFU -RC08 Common SUP, common EXH Ports 2 & 4 on valve body	
Port size	Port 1	Rc $\frac{1}{2}$ (Both sides)
	Port 3, 5	Rc $\frac{1}{2}$ (Both sides)
	Port 2, 4	Rc $\frac{3}{8}$ (Valve body)
Number of stations	2 ~ 10	
Mountable solenoid valve	RCS2408- - -MF	
	RCD2408- - -MF	
	RCD3408- - -MF	
	RCE3408- - -MF	
	RCO3408- - -MF	
Blank plate	RC08-BP	

HOW TO ORDER

Specify the type and quantity of Manifold and Solenoid Valve to be mounted, and the quantity of Blank Plate (RC08-BP) in accordance with the following example of description.

(Example) **MFU8-RC08-03**

RCS2408-03-100G-MF	4 pcs.
RCD2408-03-100G-MF	2 pcs.
RCD3408-03-100G-MF	1 pc.
RC08-BP	1 pc.

ORDERING INSTRUCTION

Manifold

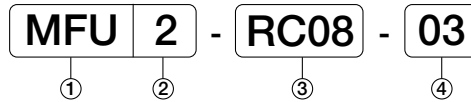

① Type of manifold

MFU	Common SUP, common EXH Ports 2 & 4 on valve body
-----	---

③ Mountable solenoid valve

RC08	RC08 series
------	-------------

② Number of stations

2	2 station
⋮	⋮
20	10station

④ Size of ports 2 and 4

03	Rc ³ / ₈
----	--------------------------------

Mountable solenoid valve (For details refer to Pages 39 to 42.)

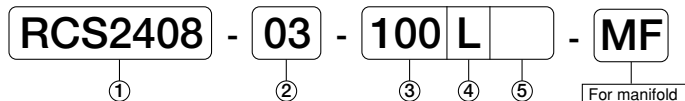

① Model No.

RCS2408	
RCD2408	
RCD3408	
RCE3408	
RCO3408	

④ Wiring

L	Lead wire
G	Grommet with terminal
C	Conduit with terminal
GK	Grommet with surge suppressor
CK	Conduit with surge suppressor
D	DIN connector

⑤ Manual override

No mark	Standard (None locking)
L	With locking button

: Made to order

② Port size

03	Rc ³ / ₈
----	--------------------------------

③ Voltage

100	AC100/110V
200	AC200/220V
D24	DC24V

RC08 Series

DIMENSIONS

MFU -RC08

(Unit : mm)

(Note) Standard manifold is plugged on " R " (Right) side ports.

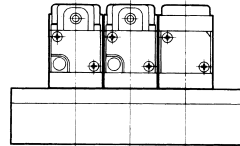
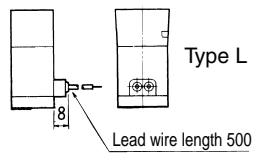
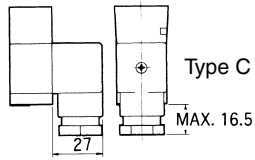
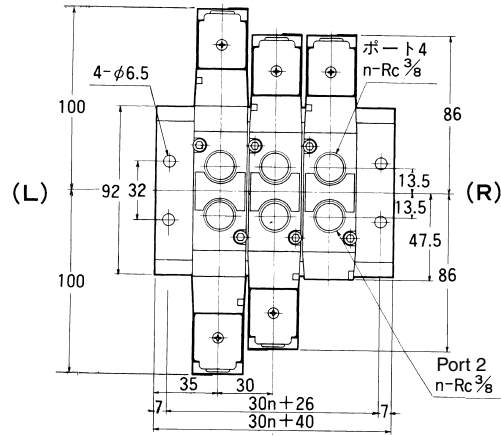
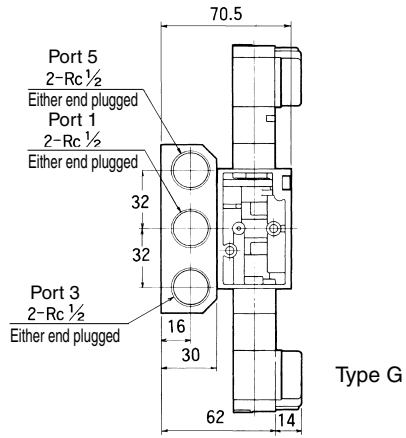



WARNING

FAILURE OR IMPROPER SELECTION OR IMPROPER USE OF THE PRODUCTS AND/OR SYSTEMS DESCRIBED HEREIN OR RELATED ITEMS CAN CAUSE DEATH, PERSONAL INJURY AND PROPERTY DAMAGE.

This document and other information from KURODA PRECISION INDUSTRIES LTD. and authorized distributors provide product and/or system options for further investigation by users having technical expertise. It is important that you analyze all aspects of your application, including consequences of any failure and review the information concerning the product or system in the current product catalog. Due to the variety of operating conditions and applications for these products or systems, the user, through its own analysis and testing, is solely responsible for making the final selection of the products and systems and assuring that all performance, safety and warning requirements of the application are met.

The products described herein, including without limitation, product features, specifications, designs, availability and pricing, are subject to change by KURODA PRECISION INDUSTRIES LTD. at any time without notice.

KURODA PRECISION INDUSTRIES LTD.

Head Office: 239, Shimohirama, Saiwai-ku, Kawasaki, Kanagawa 212-8560, Japan
Telephone: 044-555-3805
Fax: 044-555-1479
<http://www.kuroda-precision.co.jp/e-top>

Chicago Office: 9400 West Foster Avenue, Suite 108, Chicago, Illinois 60656 U.S.A.
Telephone: 773-992-2178
Fax: 773-625-8781

CAT. No. **KPL1002-@**

Distributors: